

Interactive System
インタラクティブシス
テム特論(4)

Hiroyuki Kajimoto
kajimoto@hc.uec.ac.jp
Twitter ID kajimoto
Hash tag #itsys

Schedule

- 4/11 講義(lecture)1
- 4/18 出張のため休講
- 4/25出張準備のため休講
- 5/2出張のため休講
- 5/9講義(lecture)3
- 5/16講義(lecture)4
- 5/23講義(lecture)5
- 5/30講義(lecture)6
- 6/6講義(lecture)7
- 6/13講義(lecture)8
- 6/20プレゼンテーション(presentation)1
- 6/27 出張のため休講
- 7/4プレゼンテーション(presentation)2
- 7/11プレゼンテーション(presentation)3
- 7/18プレゼンテーション(presentation)4
- 7/25 出張のため休講の可能性(未確定)
- 8/1 14 予備日

Outline of the lecture

1. 人間計測手法／Measuring Human
2. 視覚／Human Vision System
3. 視覚センシング／Visual Sensing
4. 視覚ディスプレイ／Visual Display
5. 聴覚、聴覚インタフェース／Auditory Interface
6. 触覚、触覚インタフェース／Tactile Interface
7. 力覚、力覚インタフェース／Haptic Interface
8. 移動感覚インタフェース／Locomotion Interface

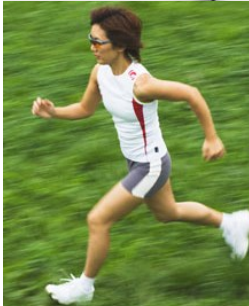
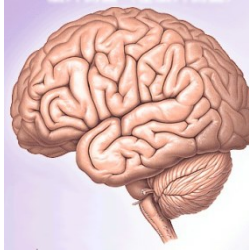

Mechanical - Mechanical

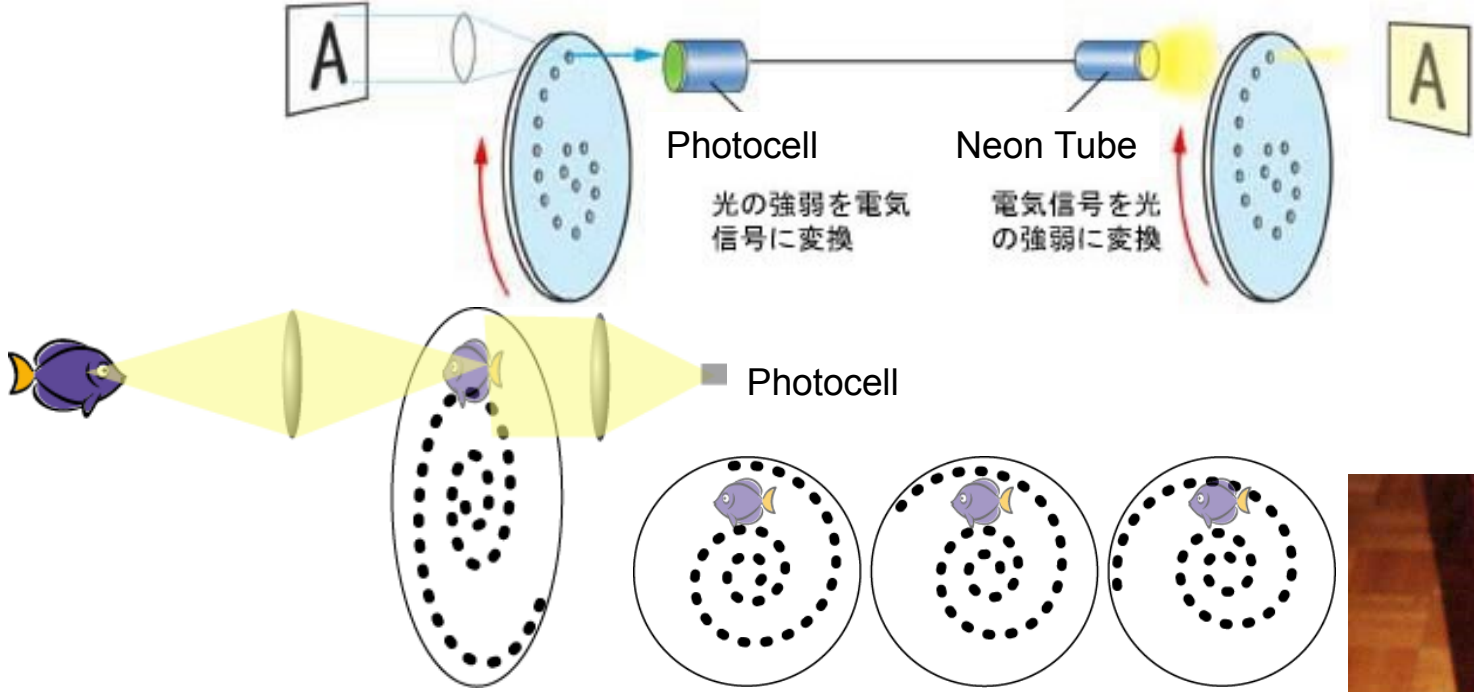

- 1877 Proposed Mechanical Scanning
- 1884 Invented Circular Mechanical Scanner
- 1925 Mechanical TV system was achieved
- 1897 Cathode-ray tube (CRT) was invented
- 1911 Cathode-ray tube was used to display a simple image.



Electrical - Electrical



1927 All electrical system was achieved.

1929 BBC starts experimental TV broadcast.

1935 Germany starts first periodical TV broadcast, and was used for Berlin Olympics



Electrical - Electrical



2011/1/20 google

大正15年(1926年)高柳健次郎

From 2D to 3D

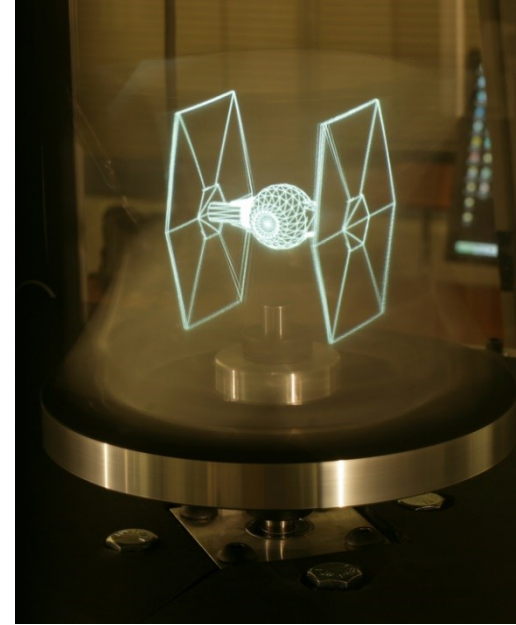
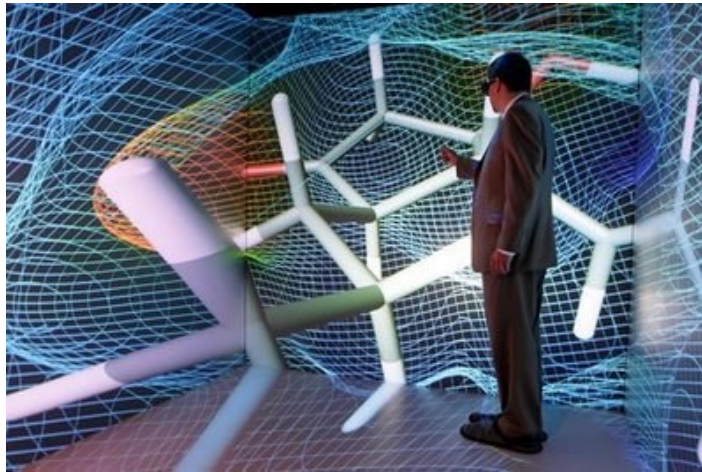

- 3D: **奥行き**の提示
Stereoscope display can present **Depth**
- = 自己と対象の**距離**の提示
Distance between image and myself is perceivable.
- つまり3Dディスプレイは対象を映すばかりでなく、自己を含んだ系を完成させる
The image is not only **a thing to view and appreciate**, but it becomes **a world in which "I" myself am included**.

TODAY'S TOPIC

- 3Dディスプレイ／3D Display
 - HMD
 - HMDとカメラ／HMD & Camera
 - HMDとAR／HMD & AR
 - 環境型／Environmental Display
 - メガネあり／With Eyeglasses
 - 環境型とカメラ／Environmental Display & Camera
 - メガネなし／Without Eyeglasses
 - 左右の目に違う映像を入れる／Input Different Images to Two Eyes
 - ボリュームメトリックな再構成／Volumetric Reconstruction
 - 光線群の制御による多視点映像／Ray Reconstruction
 - 錯覚を利用する／Using Illusion
- その他の話題
 - 光線群制御からCSCWへ／From Ray Control to CSCW
 - 光線群視点制御から視線制御へ／From Ray Control to Eye Control

Two types of 3D displays

- HMD / Head Mounted Display
- 設置型 / Ground-Fixed Display

Seems not so different?? It is very, very different.



Head Mounted Display (HMD)

- Sutherland "The Ultimate Display" (1965)

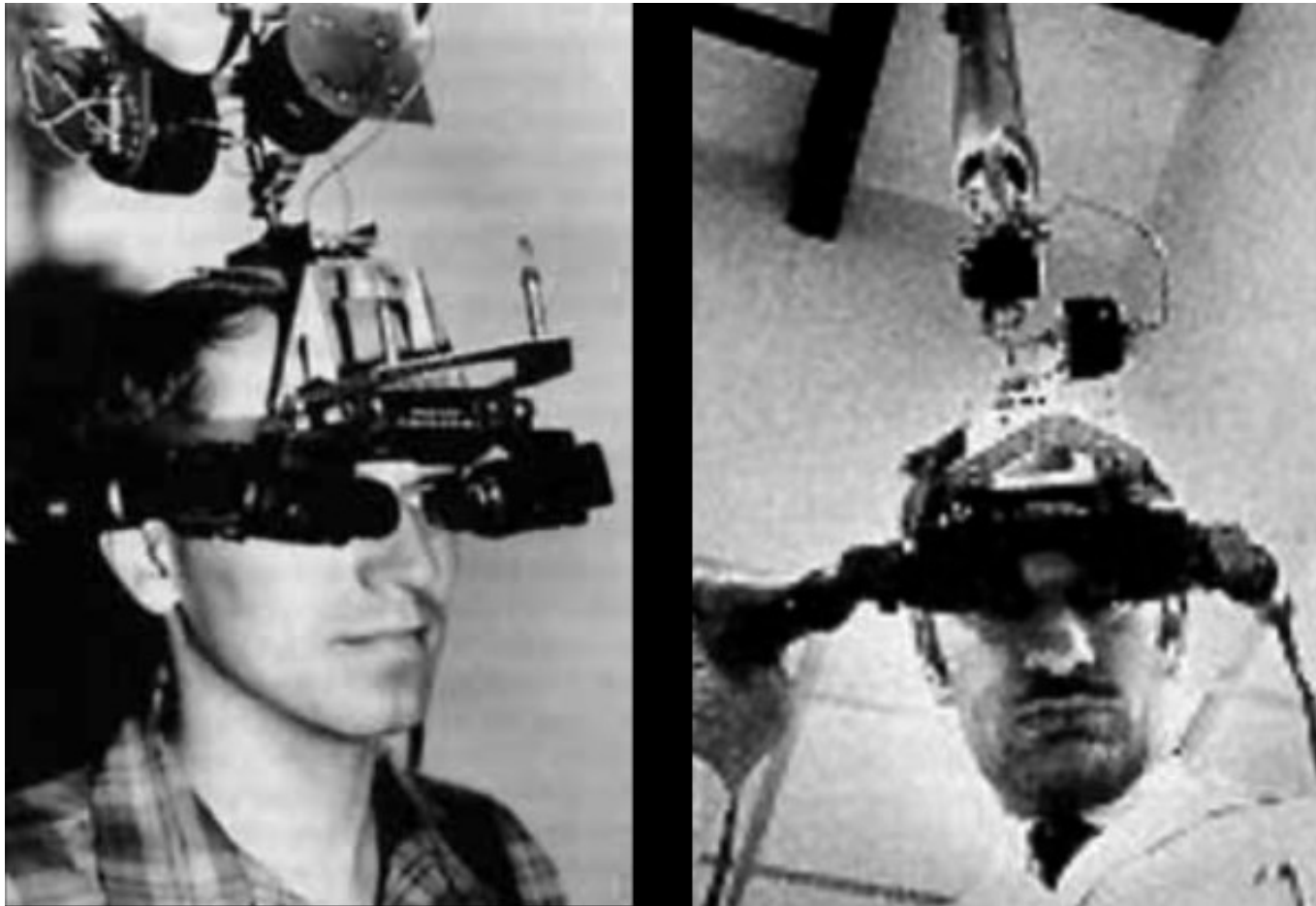

The Ultimate Display (Sutherland 1965)

- We live in a physical world whose properties we have come to know well through long familiarity. We sense an involvement with this physical world which gives us the ability to predict its properties well. For example, we can predict where objects will fall, how well known shapes look from other angles, and how much force is required to push objects against friction. We lack corresponding familiarity with the forces on charged particles, forces in non-uniform fields, the effects of nonprojective geometric transformations, and high-inertia, low friction motion. A display connected to a digital computer gives us a chance to gain familiarity with concepts not realizable in the physical world. It is a looking glass into a mathematical wonderland.
- The ultimate display would, of course, be a room within which the computer can control the existence of matter. **A chair displayed in such a room would be good enough to sit in.** **Handcuffs displayed in such a room would be confining,** and **a bullet displayed in such a room would be fatal.** With appropriate programming such a display could literally be the Wonderland into which Alice walked.

師匠と弟子

Master and Apprentice

- C. E. Shannon
Father of Information Theory
(Have you heard of “Entropy”?)
- Apprentice
 - Ivan Sutherland
**Father of Computer Graphics, and
Father of Virtual Reality**
Invented most part of fundamental
CG technique, and the first HMD
- Grand-Apprentice
 - Jim Clark: Founder of SGI and
Netscape
 - Alan Kay: Proposed the notion of
personal computer “Dynabook”

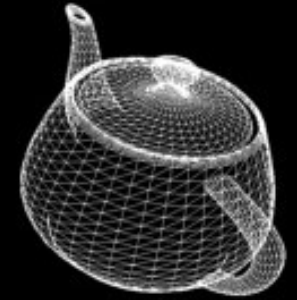
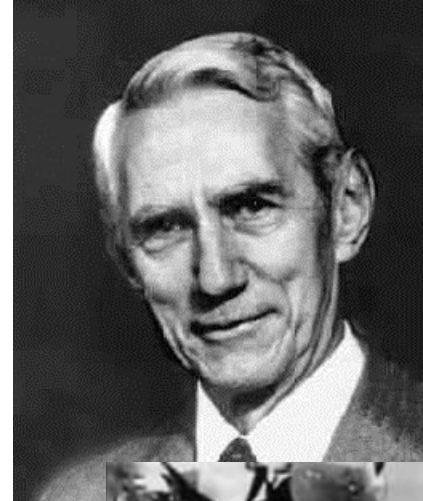

Netscape®



HMDは虫眼鏡／HMD as a magnifying glass

- 両眼に異なる映像
Two separate images are displayed to each eye.
- 頭部位置計測必須
Head position is tracked by,
Mechanical Link,
Gyro
Acceleration Sensor
Magnetic Sensor
etc...
- 虫眼鏡光学系で距離を稼ぐ
“Magnifying glass” optics is used to keep distance
between eye and image.

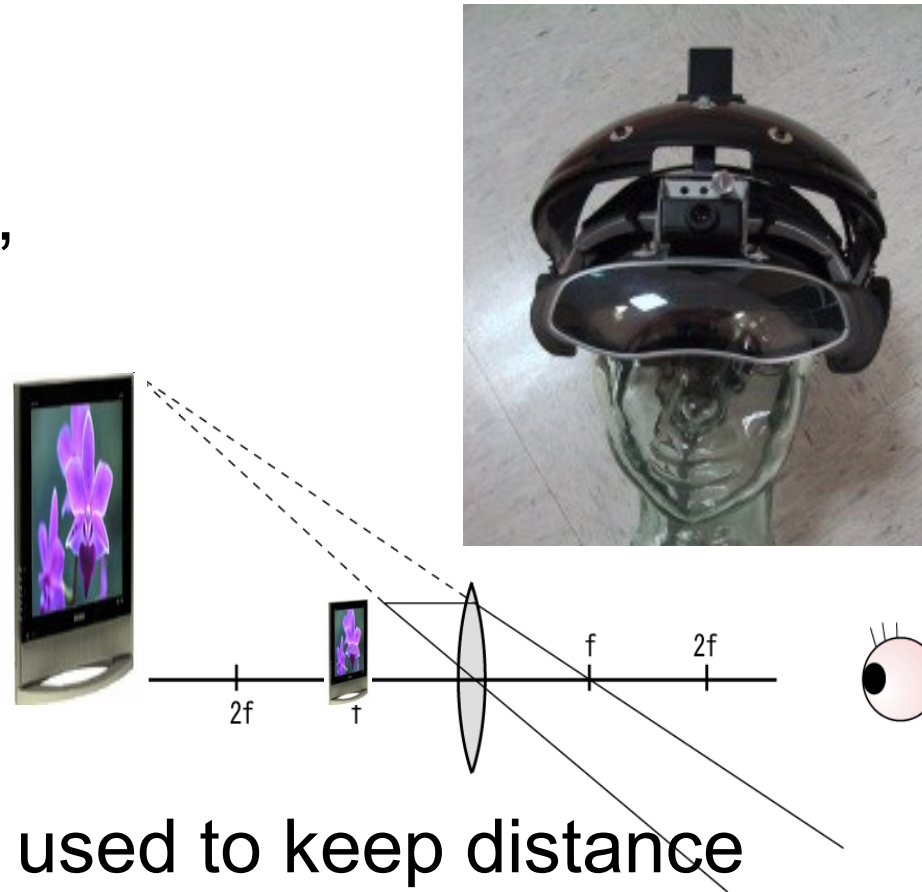

TODAY'S TOPIC

- 3Dディスプレイ／3D Display
 - HMD
 - HMDとカメラ／HMD & Camera
 - HMDとAR／HMD & AR
 - 環境型／Environmental Display
 - メガネあり／With Eyeglasses
 - 環境型とカメラ／Environmental Display & Camera
 - メガネなし／Without Eyeglasses
 - 左右の目に違う映像を入れる／Input Different Images to Two Eyes
 - ボリュームメトリックな再構成／Volumetric Reconstruction
 - 光線群の制御による多視点映像／Ray Reconstruction
 - 錯覚を利用する／Using Illusion
- その他の話題
 - 光線群制御からCSCWへ／From Ray Control to CSCW
 - 光線群視点制御から視線制御へ／From Ray Control to Eye Control

HMD用のカメラとは？ / Camera for HMD?

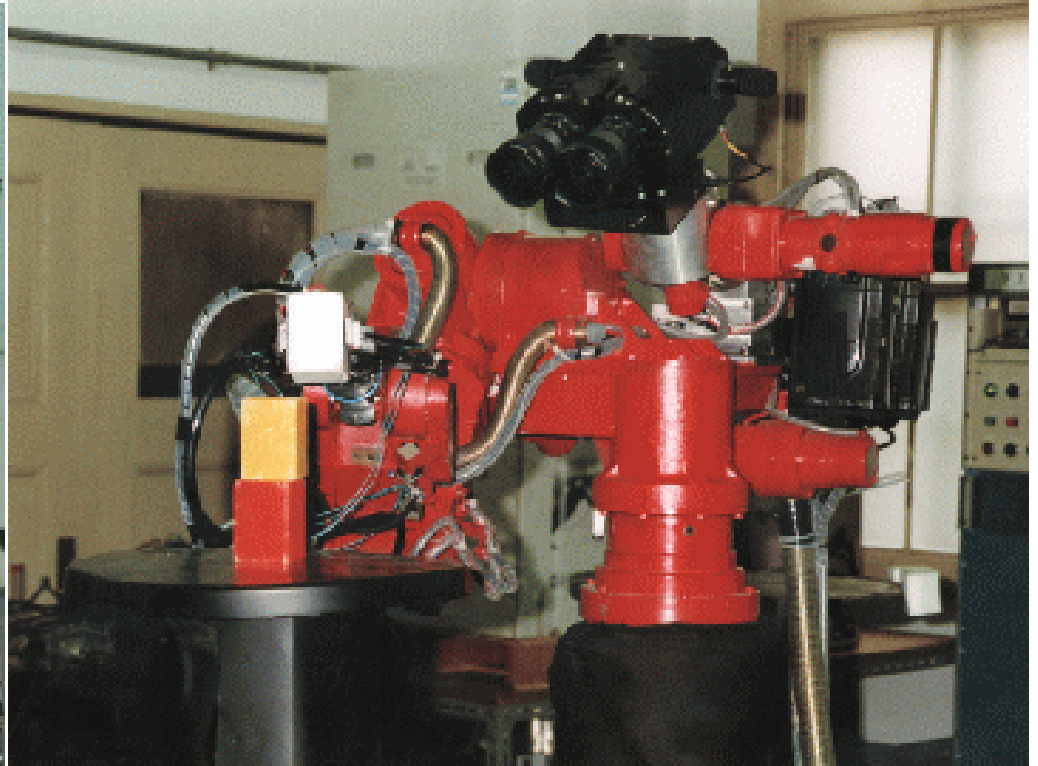
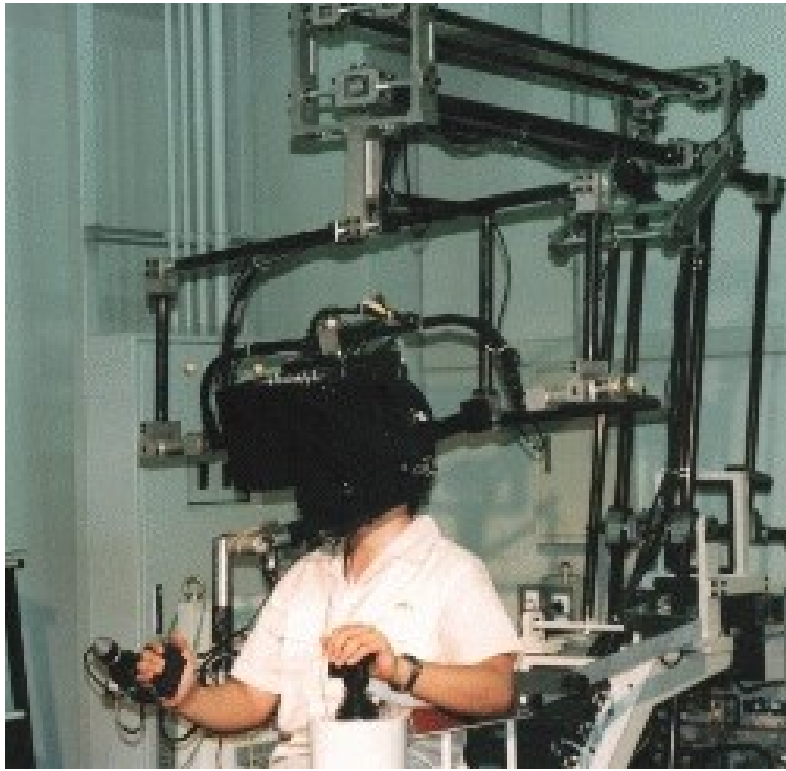

- Two cameras, which are at the same position as the HMD are used.

TELESAR (Tachi et al., 1989)

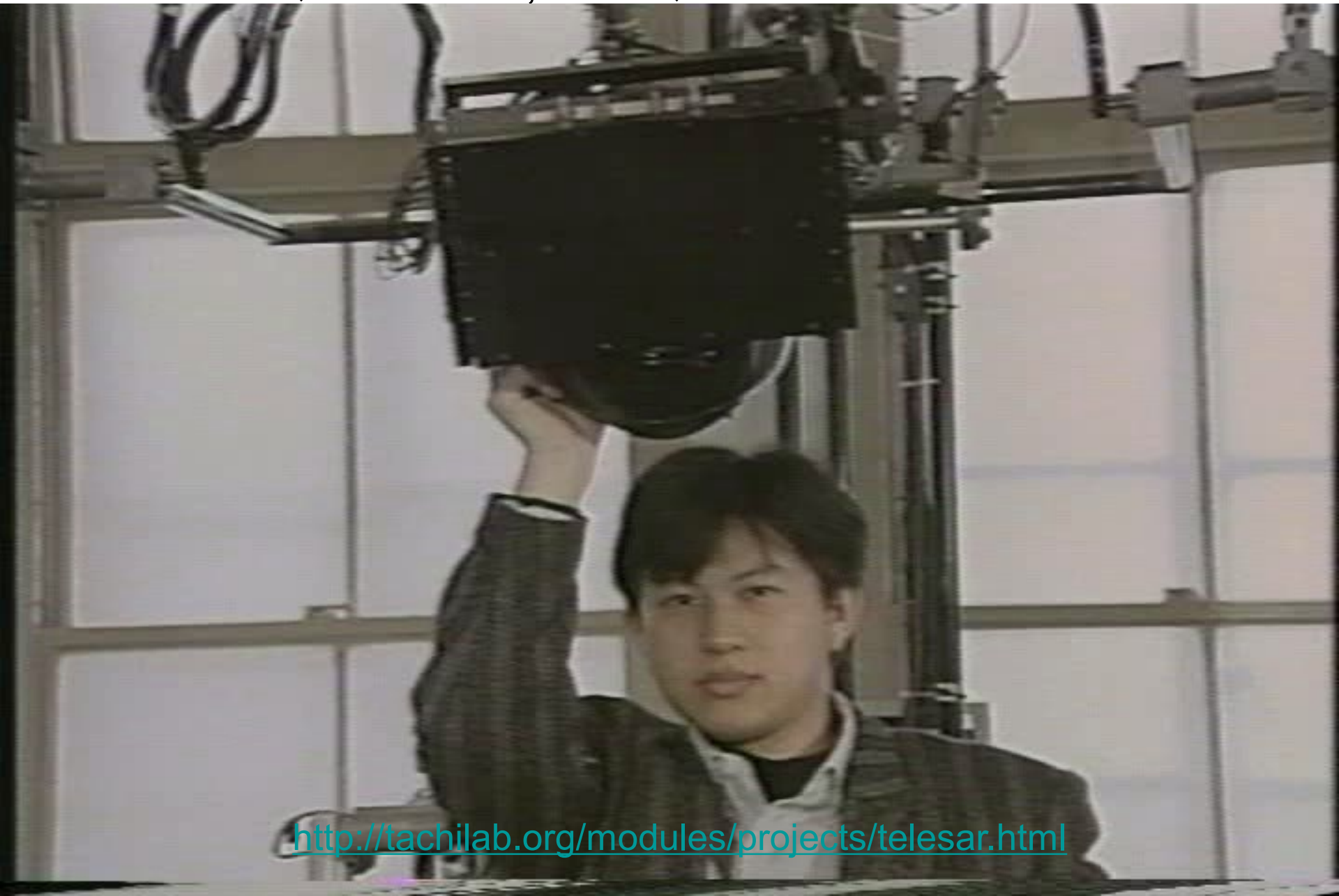

<http://tachilab.org/modules/projects/telesar.html>

Torso (Watanabe et al. 2007)

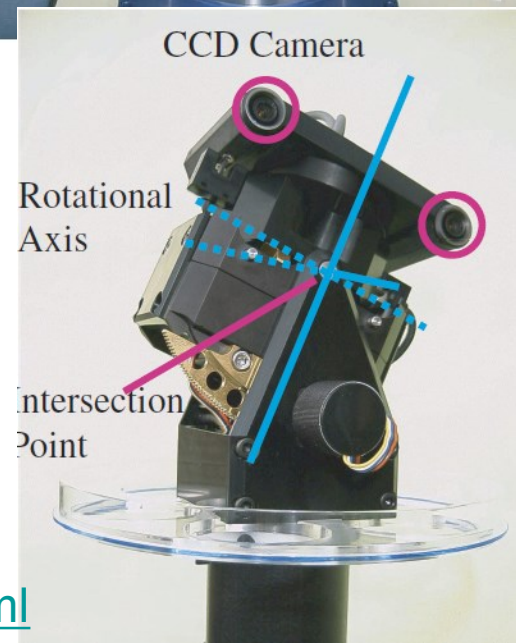
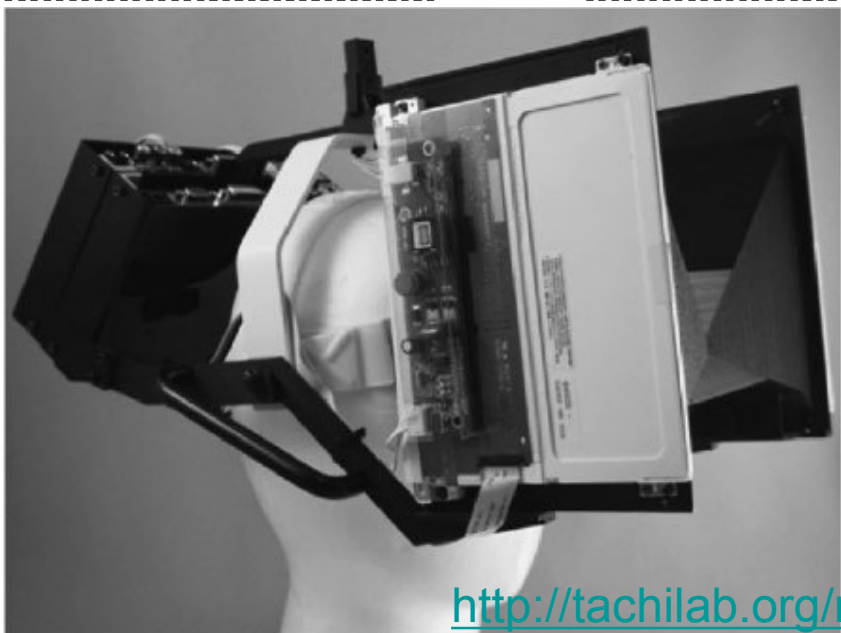
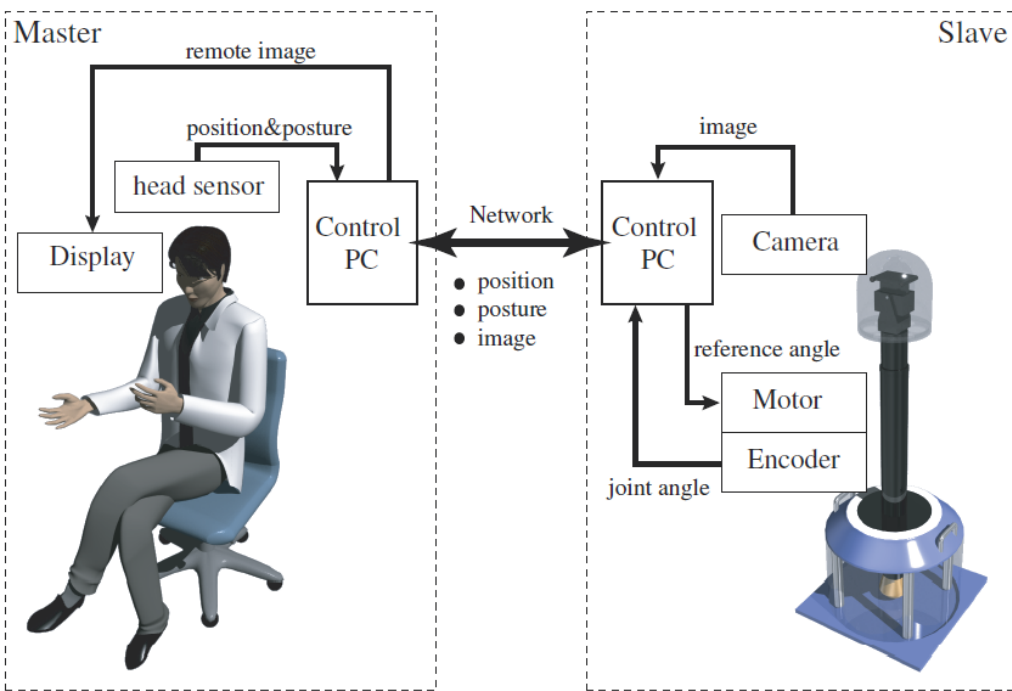

Torso (Watanabe et al. 2007)

TORSO

Completion of
egocentric telegnosis system

<http://tachilab.org/modules/projects/torso.html>

頭部回転？問題なし

Head Rotation? No problem!!

Robot Camera

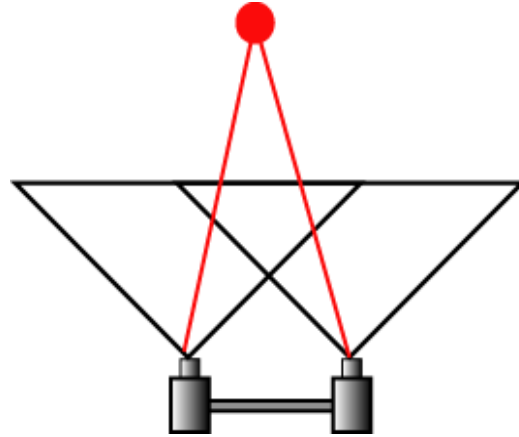

HMD

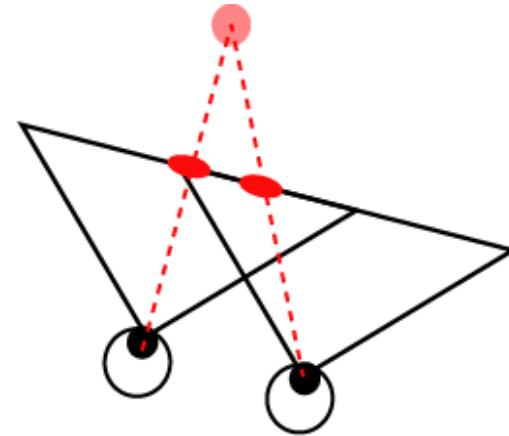
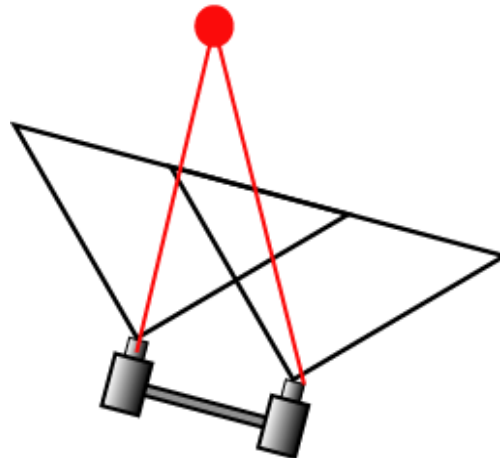
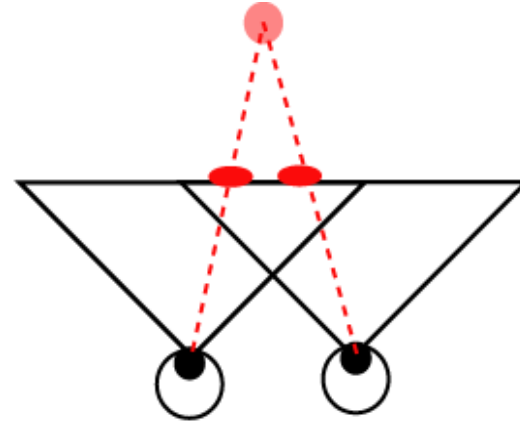

Seems obvious??

その他の注意点(1) 眼間距離と視野角の問題

Other concerns(1) Eye distance & view angle

- 眼間距離(カメラ間距離)の不一致: 両眼立体視を行うと自分が巨人or 小人になったかのような感覚. (立体視おもちゃの「箱庭感」)
Difference of eye distances generate odd size feeling (miniature garden)

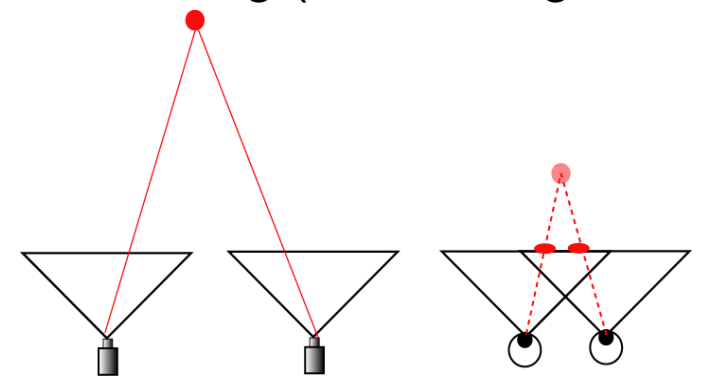
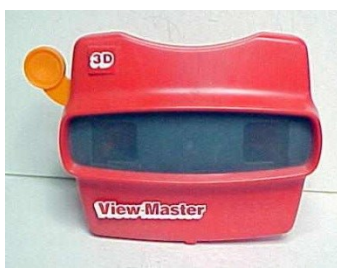

- 視野角の不一致 / Difference of viewing angle

- 奥行きがおかしくなる. Distance is changed
- 頭部回転運動の際, 正面の物体が観察者の頭にくっついて動くか, 逆方向に流れる. When head rotates, objects “move”.
- 眼鏡を初めてかけたときの違和感

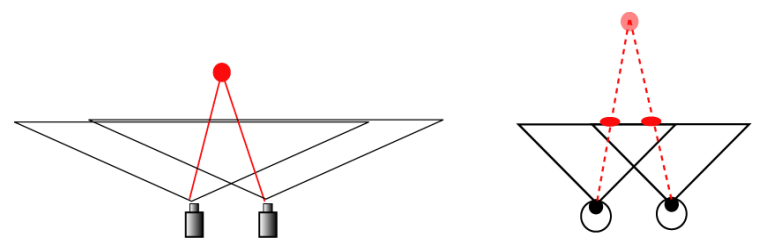

その他の注意点(2) 時間遅れの問題

Other concerns(2) Time Latency

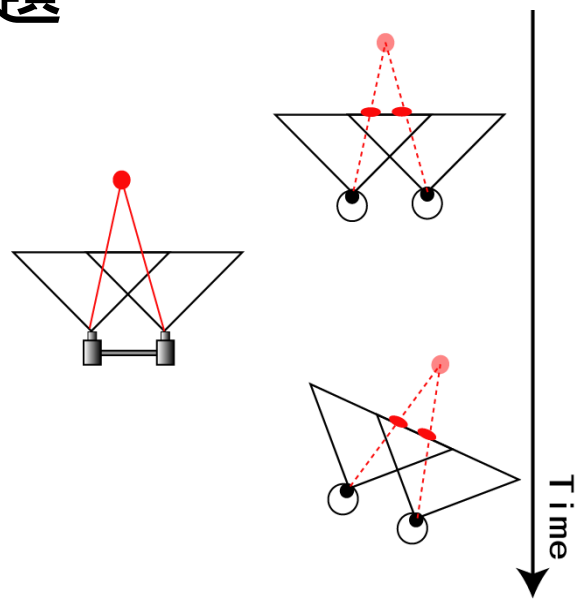
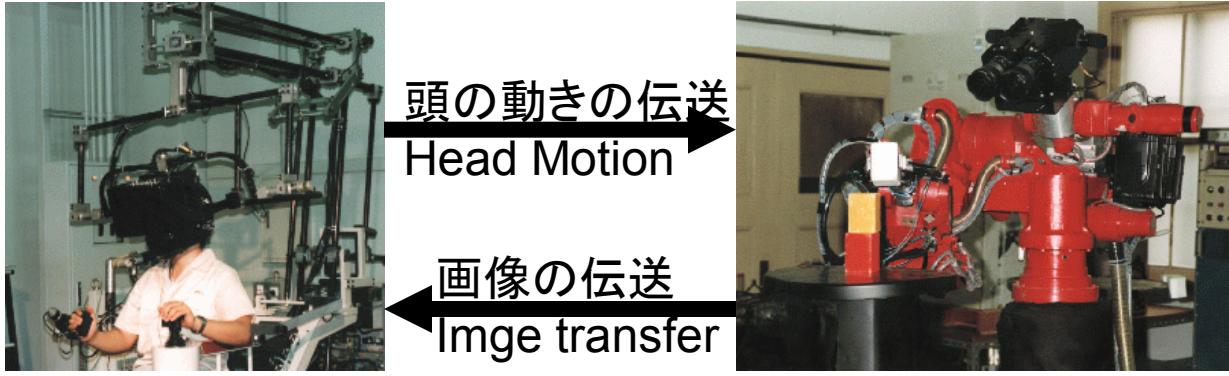

- 頭の動きから描画までに時間遅れ.
Latency between head motion and image display

- 首を振ったとき When the head rotates:

- HMD:

- 画像が首の回転に付いてくる
The image **moves**

- 設置型 Ground fixed display:

- 画像は付いてこない. しかし立体視に関しては狂い, 奥行き方向にひずみを生じる.
The image does not move, but **distort**.

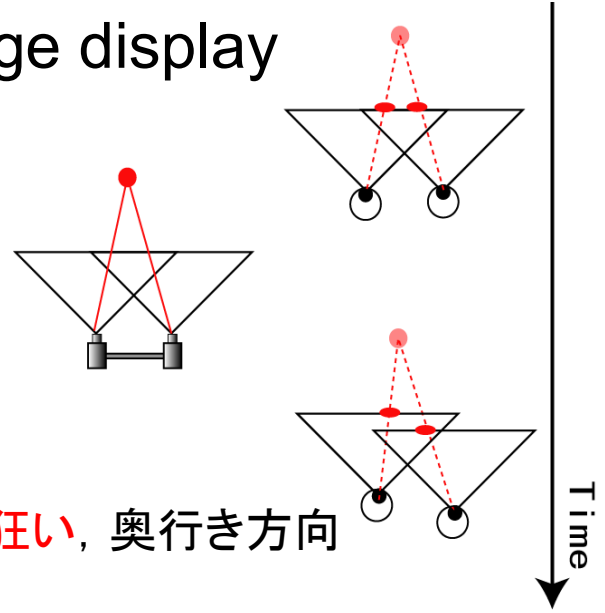

HMDの利点と欠点／Pros & Cons of HMD

- 行動範囲が広い／Users can walk freely
- 自分の体を隠せるため自己投射性が高くなる。時間遅れ、座標ずれに対してロバストに／Users can hide their bodies, meaning they can “deceive” themselves. Becomes robust to latency and coordinate distortion
- 遠隔ロボット(カメラ)との相性が良い／Easy to design distance robot camera.
- 装着するので重い、閉塞感／Heavy and feeling of being caged
- 顔が隠されるため双方向コミュニケーションには不向
／Face is hidden, meaning two way communication is difficult.
- 視野角を大きくとる設計が難しい／Design of large field of view is quite difficult.

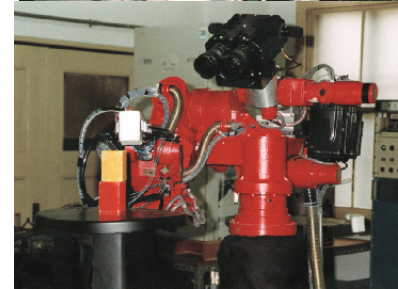
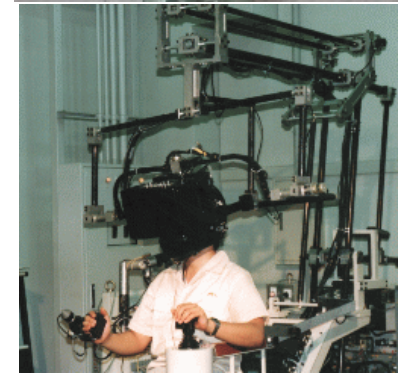

普及版HMD？ Oculus Rift(2013～)



Oculus Rift(2013～)



- 安くするための工夫

- 従来の「両眼に対応した二台のディスプレイ」ではなく、一つのディスプレイに右目、左目映像を描画
- 従来の「高価なレンズによって映像の歪みを補正する」のではなく、ディスプレイに描画する時点で逆の歪みをつけて表示

- 安定化のための工夫

- 首振り運動に対する補償を行い、「頭を動かすと画像がついてくる」問題を解消

木島他, Reflex HMD : 前庭反射機能を備えたHMDの開発
A Development of - Reflex HMD - Head Mounted Display with Vestibular Reflex
日本バーチャルリアリティ学会論文誌 6(2), 107-114, 2001

TODAY'S TOPIC

- 3Dディスプレイ／3D Display
 - HMD
 - HMDとカメラ／HMD & Camera
 - HMDとAR／HMD & AR
 - 環境型／Environmental Display
 - メガネあり／With Eyeglasses
 - 環境型とカメラ／Environmental Display & Camera
 - メガネなし／Without Eyeglasses
 - 左右の目に違う映像を入れる／Input Different Images to Two Eyes
 - ボリュームメトリックな再構成／Volumetric Reconstruction
 - 光線群の制御による多視点映像／Ray Reconstruction
 - 錯覚を利用する／Using Illusion
- その他の話題
 - 光線群制御からCSCWへ／From Ray Control to CSCW
 - 光線群視点制御から視線制御へ／From Ray Control to Eye Control

Augmented Reality (AR) and See-Through HMD

- Overlap CG image and the real world
 - ビデオシースルー／Video See-Through: Capture the real world by camera.
 - オプティカルシースルー／Optical See-Through: use half-mirror & optically overlap



See-Through HMD (video see-through)

ARの問題(1)焦点調節

Problem of AR (1) Focal distance

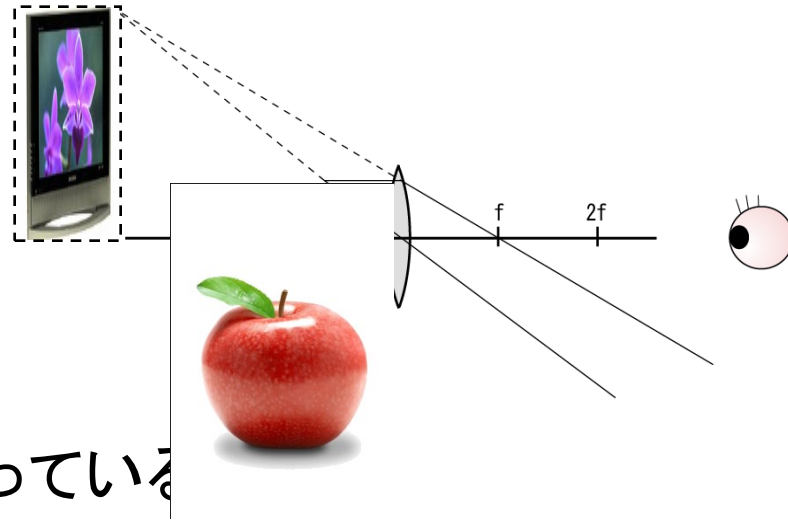

- HMD像：結像位置が決まっている

HMD image is always at the same distance.

- 実世界の物体：距離はまちまち

Distance of real world object is arbitrary

両方を同時にクリアに見ることができない

User can't clearly observe the two simultaneously.

ビデオシースルーでは問題にならないが、焦点深度の深いカメラが必要で実世界とは違ってくる

Video see-through partially solved the problem, but the real world image is different due to large depth camera.

ARの問題(2) 遮蔽

Problem of AR(2) Occlusion



A



B

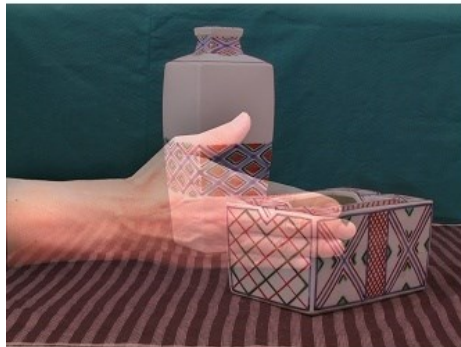

C



D

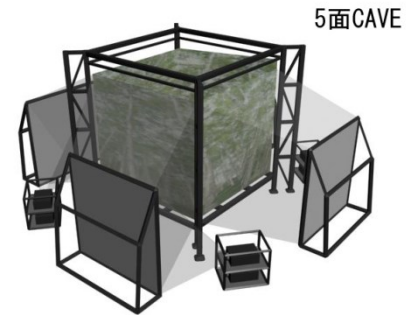

- (A) 通常のHMD. Ordinary HMD
- (B) 理想的な遮蔽状態. Ideal occlusion
- (C) See-Through HMD.
- (D) 設置型 / Ground fixed display.

網膜書き込み型HMD Retina scan display

- Washington university, HIT Lab('99)
- レーザ光線による網膜書き込み Scan retina by laser beam
 - 眼球のレンズによる結像が不要
Image focus by the eye lens is unnecessary
 - Problem of focal distance is solved.

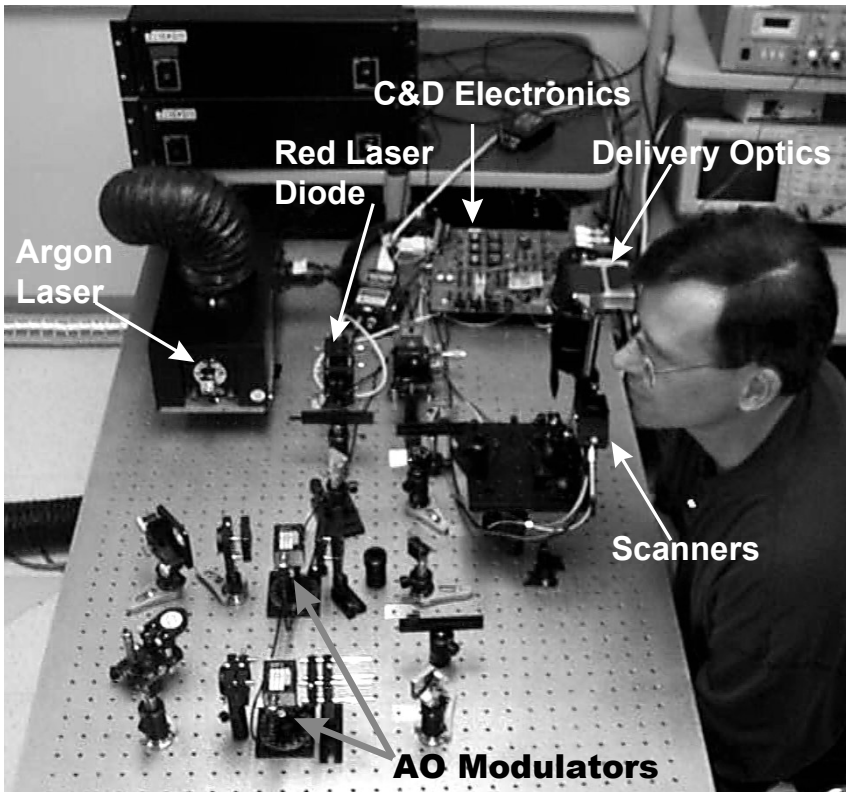
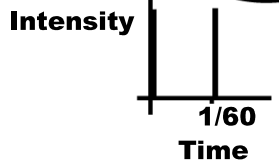
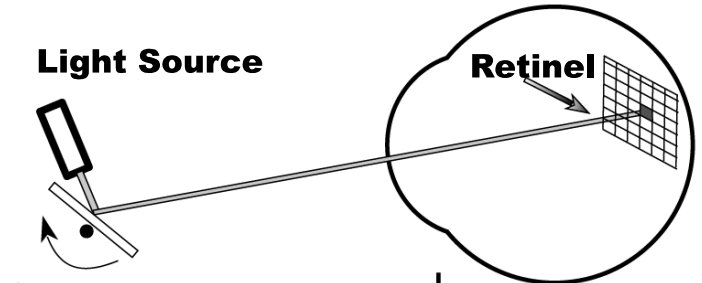
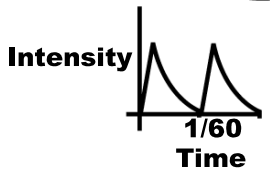
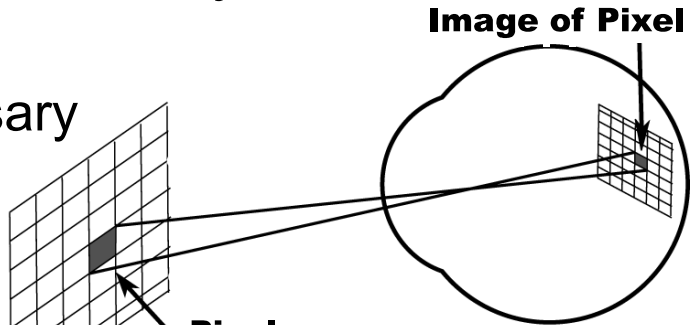

ブラザー工業の網膜走査ディスプレイ Retina Scan display by Brother Inc.

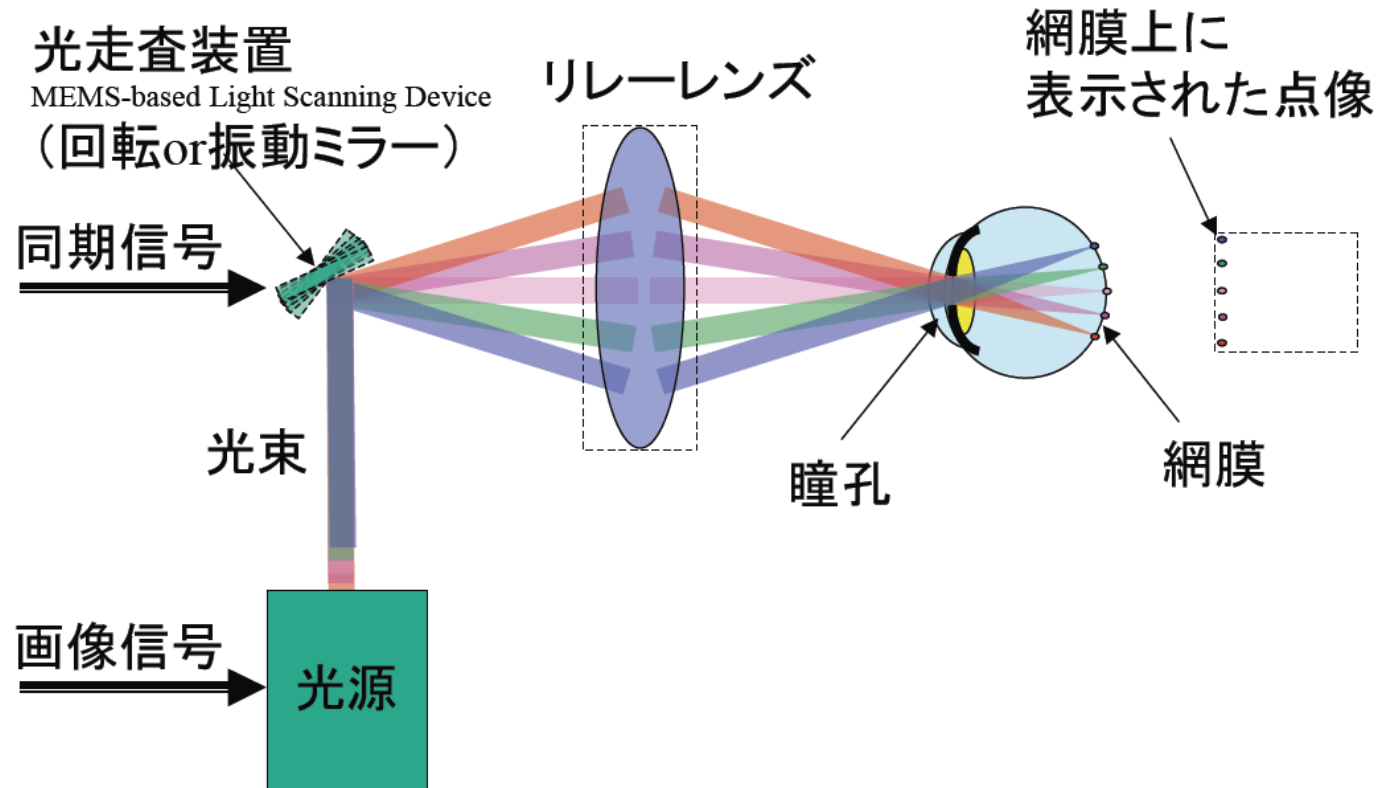

ブラザー工業の網膜走査ディスプレイ Retina scan display by Brother Inc.

www.diginfo.tv



<http://www.youtube.com/watch?v=OIAZpmaYic8>

再帰性反射材を用いた頭部搭載プロジェクタ Head Mounted Projector by Retroreflector

<http://projects.tachilab.org/rpt/>

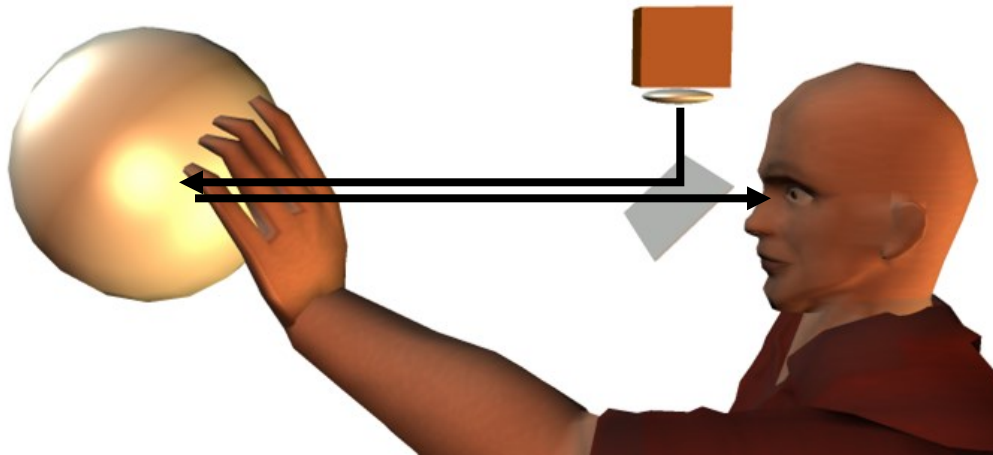
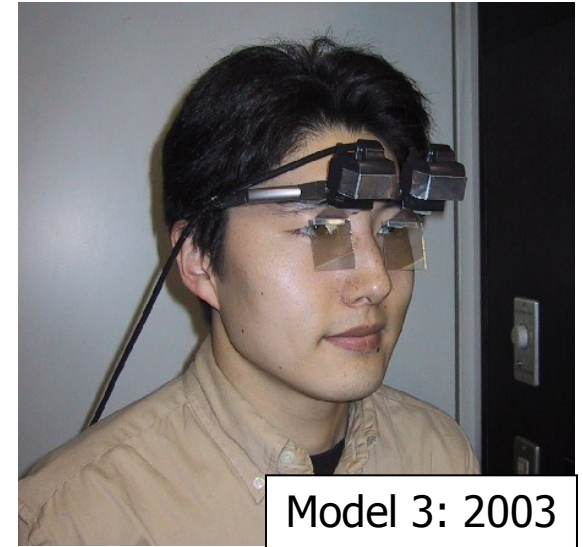
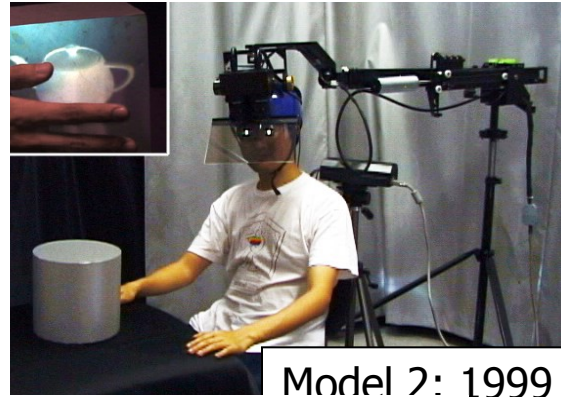

再帰性反射材

What is retro-reflector?

- Glass balls with index of refraction=2
- Or, Cube type (Corner Cube)
- Any incident beams will come back to the same direction.

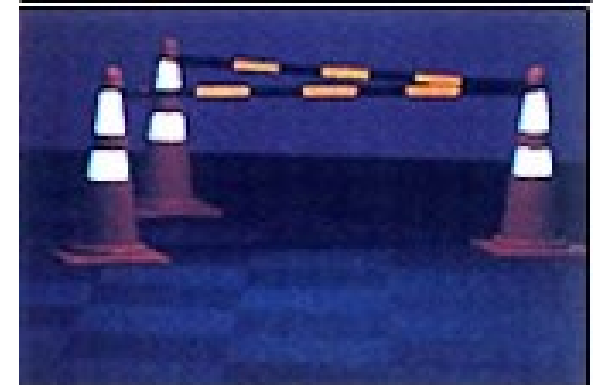
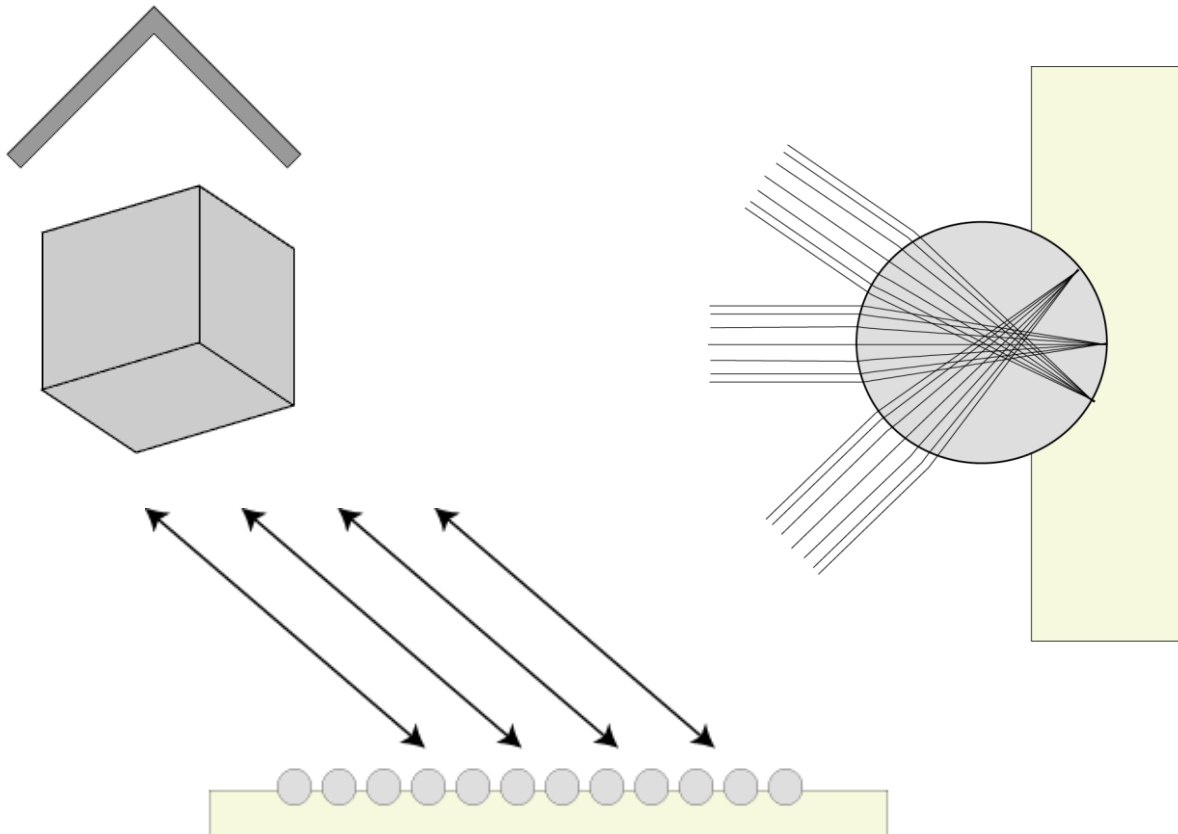
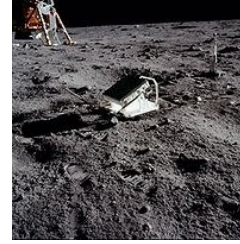

RPT: Retro-reflective Projection Technology

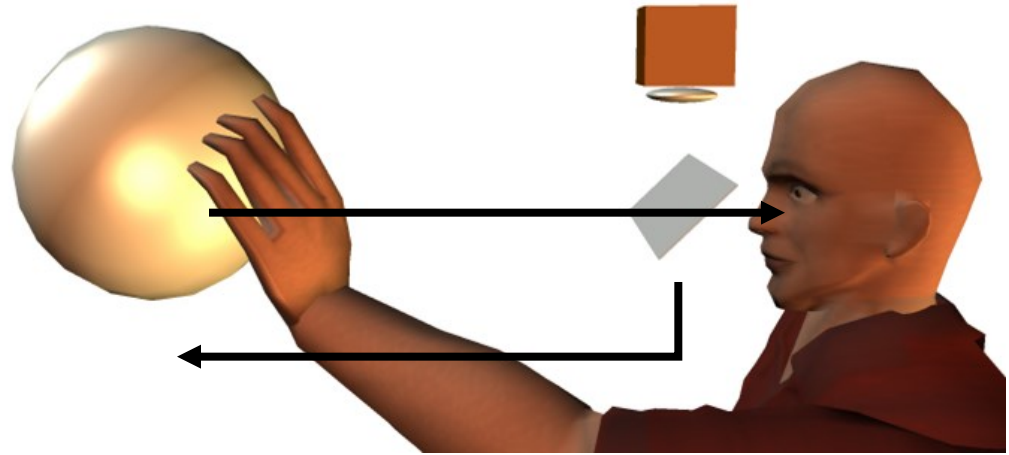
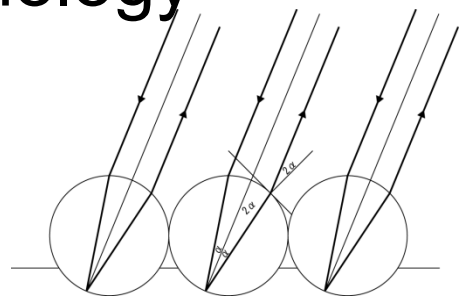
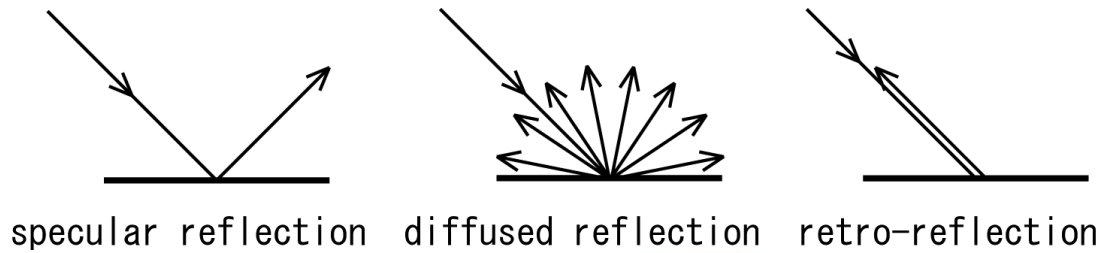

- Use retroreflector and projector
- Problem of focal distance is solved.
- Problem of occlusion is solved.
- Stereoscopic image can be presented



Tachi Lab.
Univ. of Tokyo

Optical Camouflage by RPT (Inami et al.)

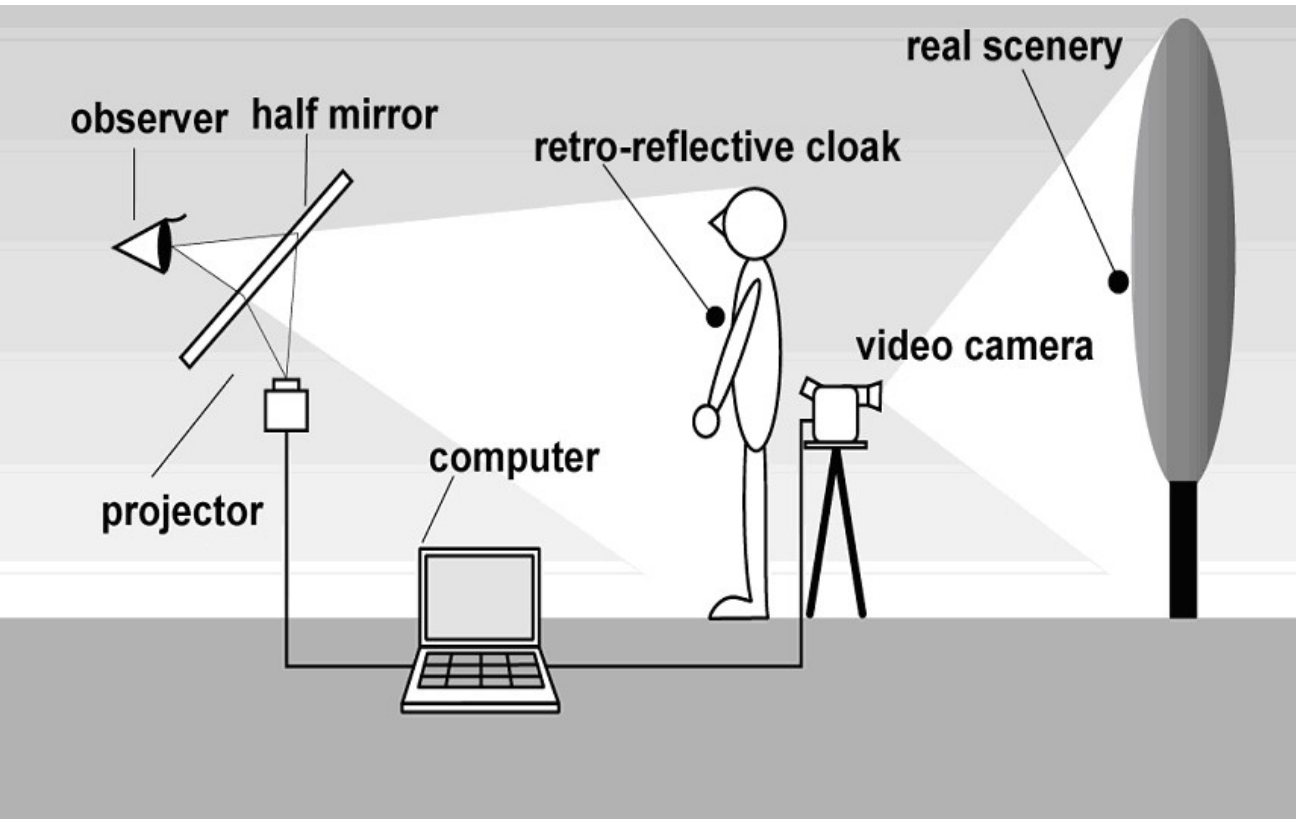

<http://www.star.t.u-tokyo.ac.jp/projects/MEDIA/xv/oc-j.html>



Robot surface becomes screen.

(Aichi World Expo 2005)

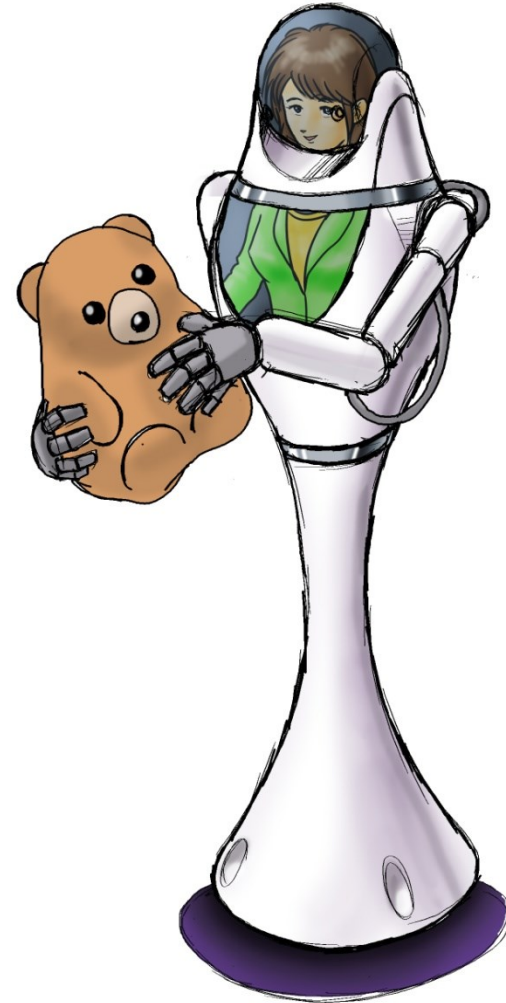
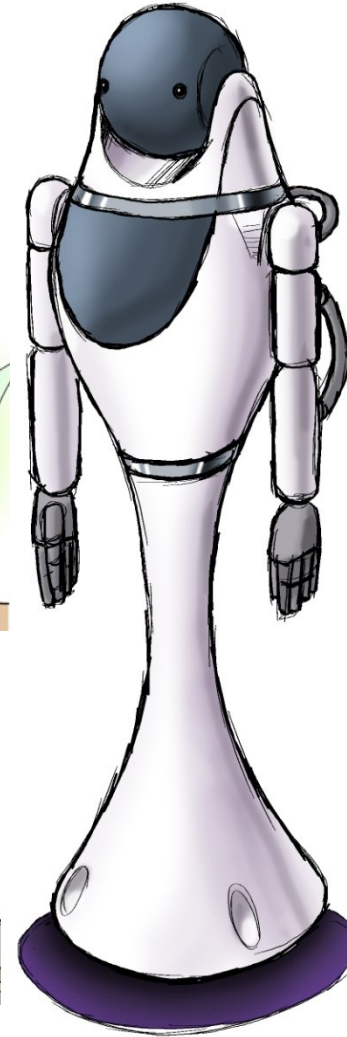
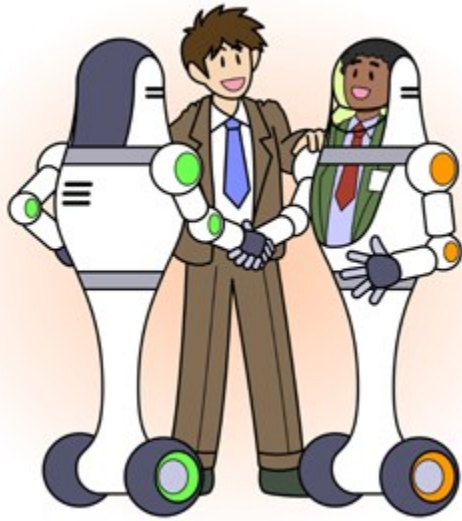



TODAY'S TOPIC

- 3Dディスプレイ／3D Display
 - HMD
 - HMDとカメラ／HMD & Camera
 - HMDとAR／HMD & AR
 - 環境型／Environmental Display
 - メガネあり／With Eyeglasses
 - 環境型とカメラ／Environmental Display & Camera
 - メガネなし／Without Eyeglasses
 - 左右の目に違う映像を入れる／Input Different Images to Two Eyes
 - ボリュームメトリックな再構成／Volumetric Reconstruction
 - 光線群の制御による多視点映像／Ray Reconstruction
 - 錯覚を利用する／Using Illusion
- その他の話題
 - 光線群制御からCSCWへ／From Ray Control to CSCW
 - 光線群視点制御から視線制御へ／From Ray Control to Eye Control

Two types of 3D displays

- HMD / Head Mounted Display
- 設置型 / Ground-Fixed Display

Seems not so different?? It is very, very different.



Ground Fixed Display

- Some sort of “Filter” is necessary to display separate image to each eyes.
- By using projectors, surrounding display possible
(IPT: Immersive Projection Technology)

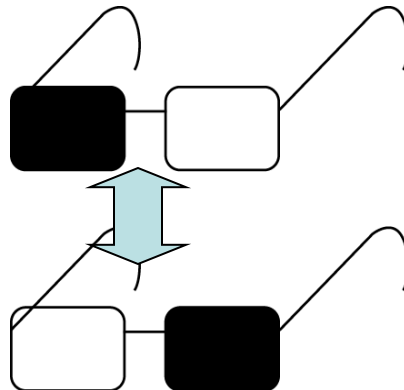
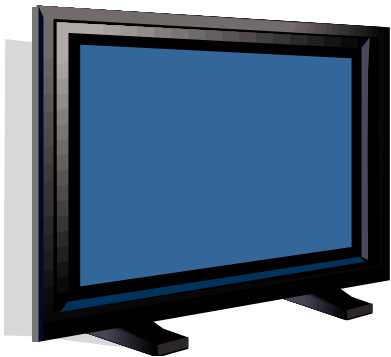
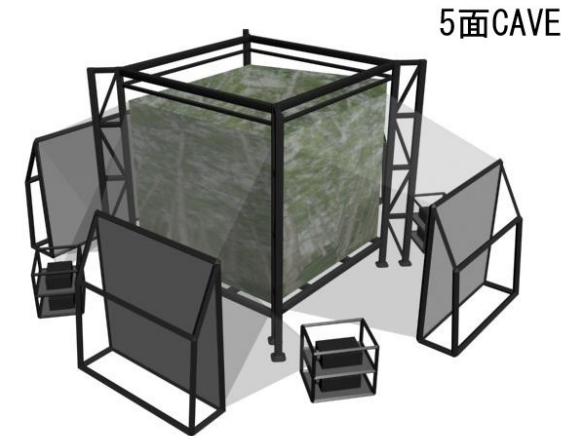

LCD shutter type IPT system: CABIN @ U-Tokyo



Filter (1) Color Filter

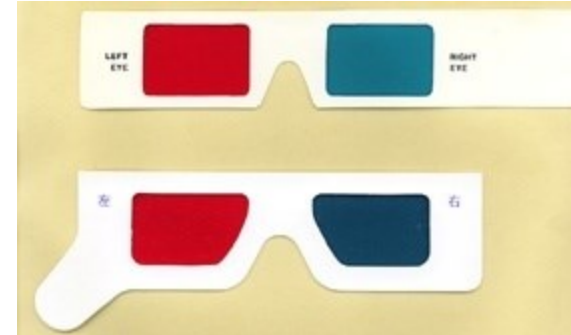

- Red cellophane and Blue cellophane. That's it.
 - \$\$Cheap!\$\$
 - Color is strange.

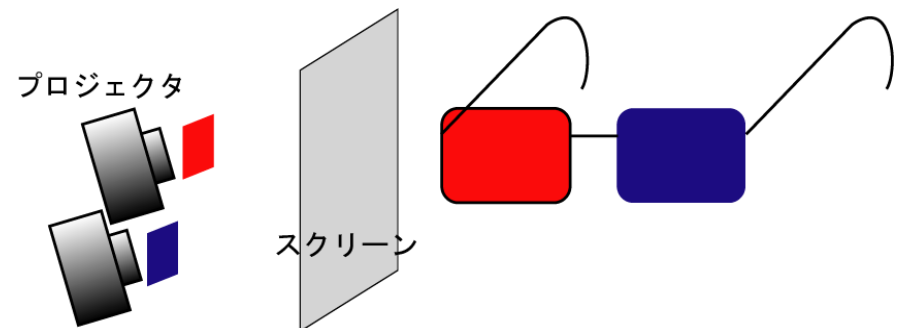

Filter (1.5) Full-color “color filter”

- Very narrow band-pass filter
 - Field of view becomes narrow
- Right-eye red, and Left-eye red is slightly shifted, but we can not know!
- **Most beautiful 3D display for current technology.**
 - “Dolby 3D” employs this method

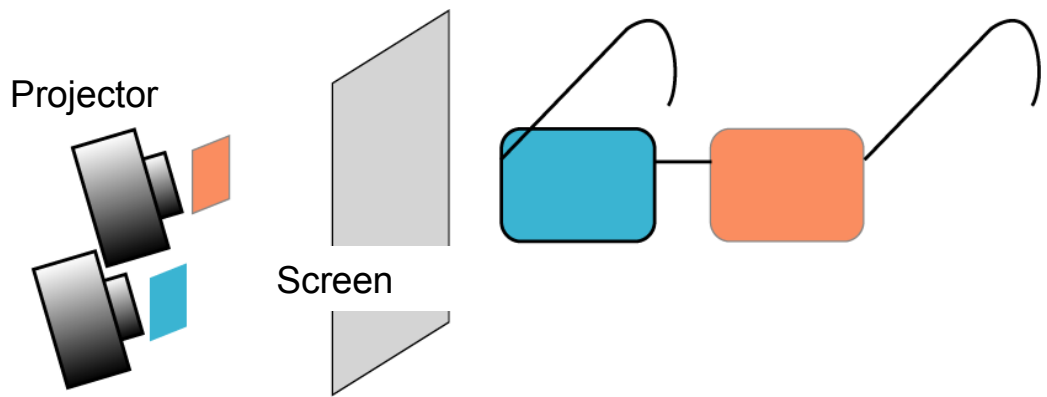
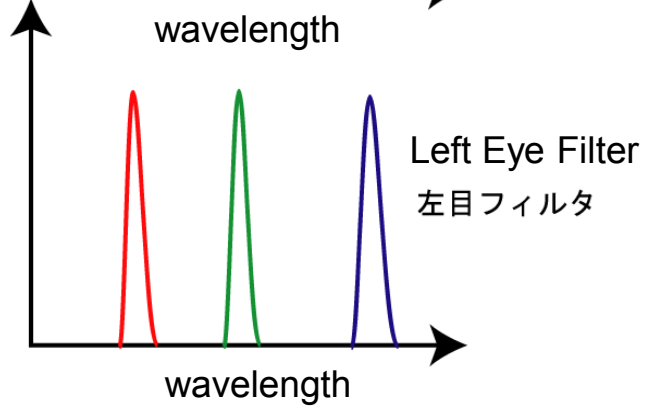
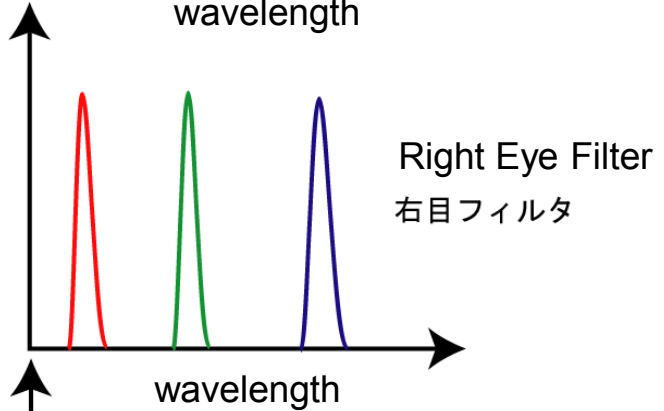
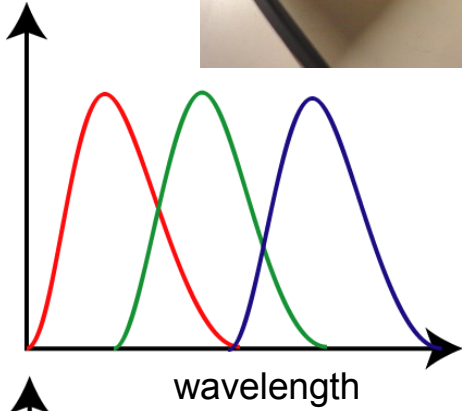

Filter (2) Polarization Filter

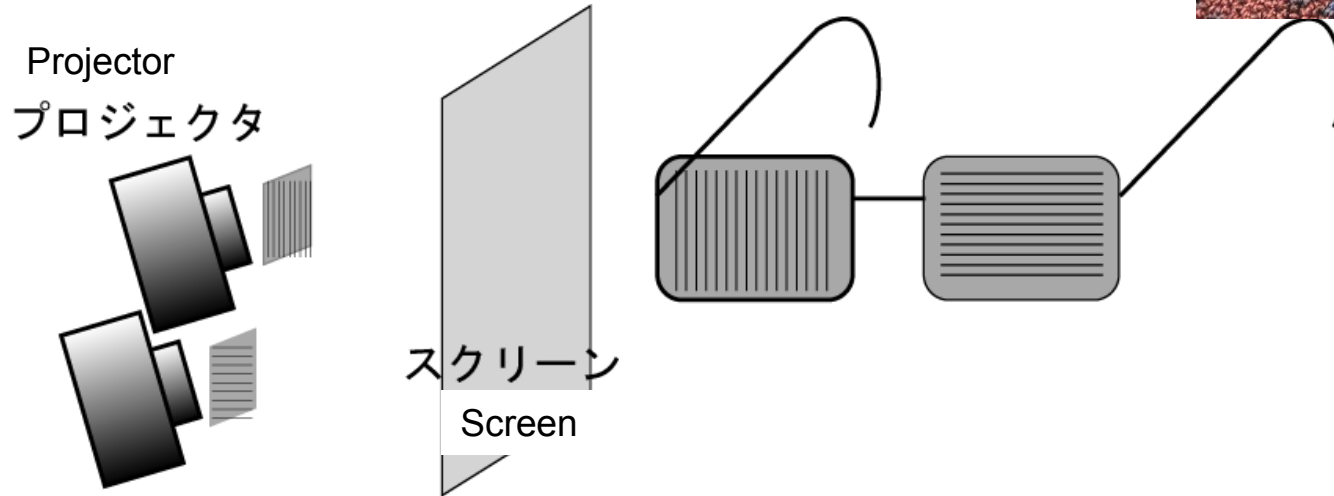

- Horizontally polarized light can not pass through vertical polarizer, and vice-versa.
- Cheap and color is OK.
- Circular polarization is used for tilt robustness.

Filter (3) Time-multiplexing

- High speed “LCD shutters” are put on each eyes.
- At one frame, only one eye can see.
- The refresh rate becomes half.
Quite high fps display is necessary (\times LCD OCRT)
- Many people can observe different image
(image becomes darker and fps becomes lower, though)

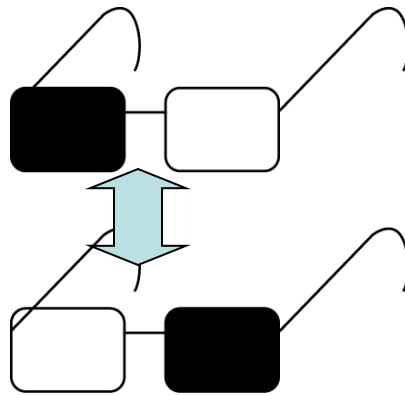
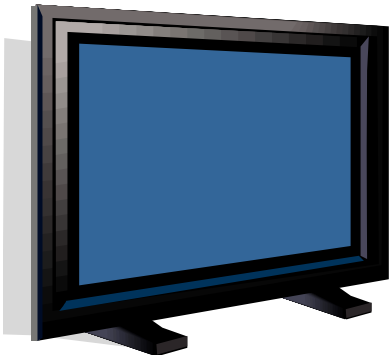

AVATAR(2009)

- いくつかの方式で同時上映された
 - XpanD: Time multiplexing
 - RealD: Polarization filter (circular)
 - Dolby3D: Full color “color filter”
 - IMAX3D: Polarization filter (linear)

<http://itsa.blog.so-net.ne.jp/2010-01-15>

- 3Dの「字幕」問題を認識させた: ARの問題に等しい
Showed problem of “caption”: Equal to AR problem



XpanD



RealD



Dolby3D



IMAX3D



TODAY'S TOPIC

- 3Dディスプレイ／3D Display
 - HMD
 - HMDとカメラ／HMD & Camera
 - HMDとAR／HMD & AR
 - 環境型／Environmental Display
 - メガネあり／With Eyeglasses
 - 環境型とカメラ／Environmental Display & Camera
 - メガネなし／Without Eyeglasses
 - 左右の目に違う映像を入れる／Input Different Images to Two Eyes
 - ボリュームメトリックな再構成／Volumetric Reconstruction
 - 光線群の制御による多視点映像／Ray Reconstruction
 - 錯覚を利用する／Using Illusion
- その他の話題
 - 光線群制御からCSCWへ／From Ray Control to CSCW
 - 光線群視点制御から視線制御へ／From Ray Control to Eye Control

HMD用のカメラを設置型ディスプレイに使うと If we use HMD camera for Ground fixed Display

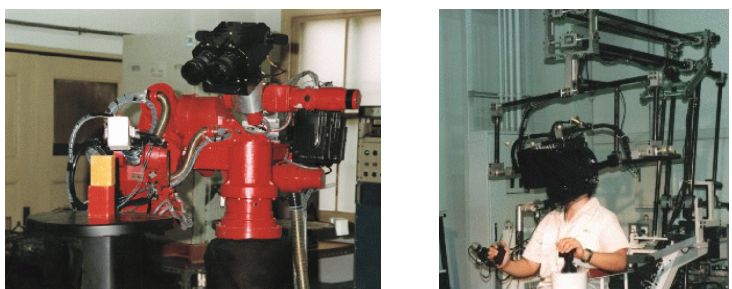

HMD system

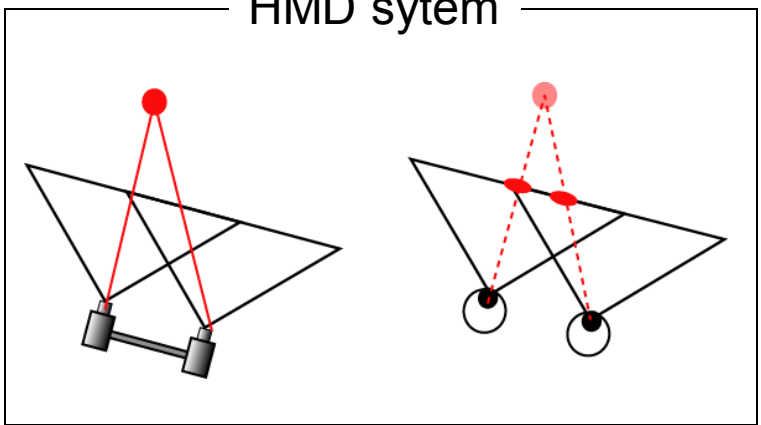

HMDcam

Ground fixed Display

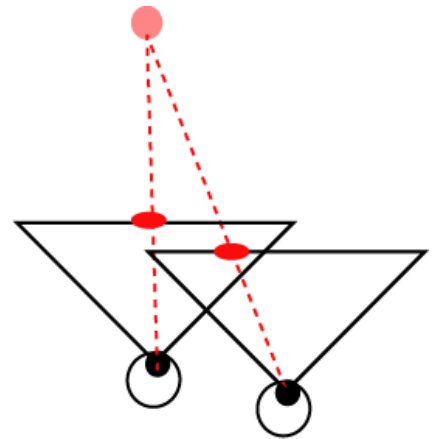
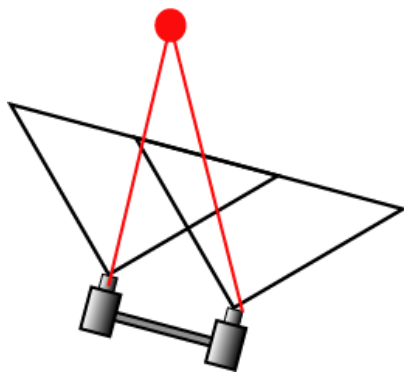
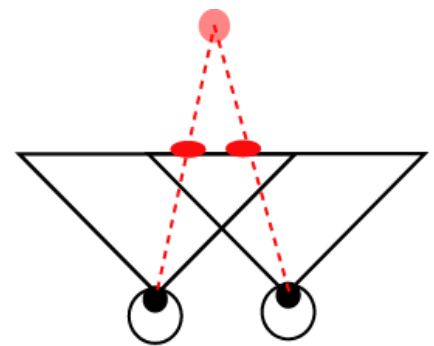
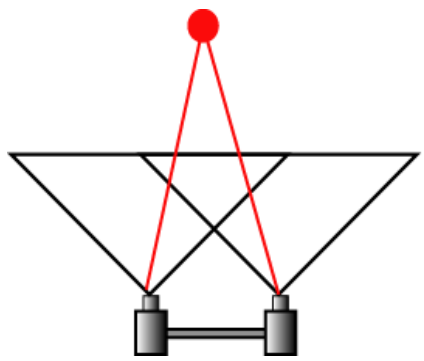

Head rotation change position and distance
= The world is twisted

(参考) 設置型ディスプレイ用カメラ (Yanagida et al. 1999)

Camera for Ground Fixed display

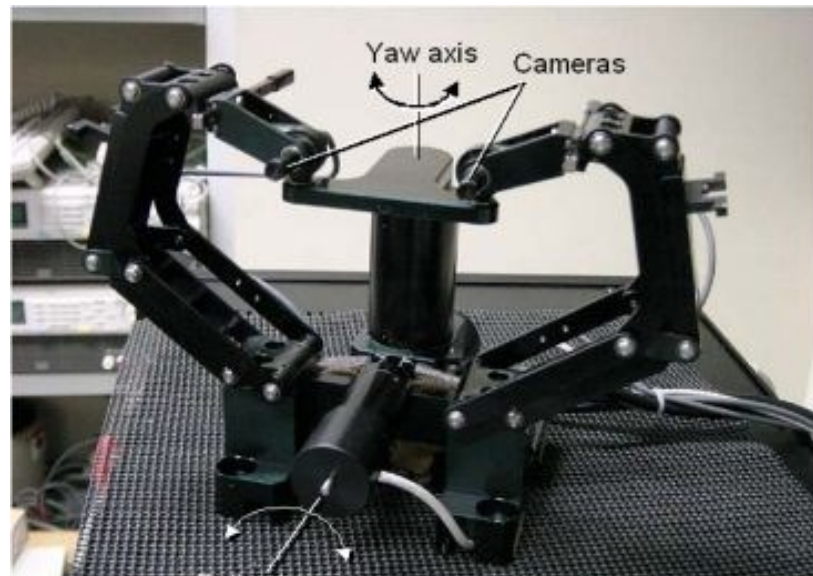
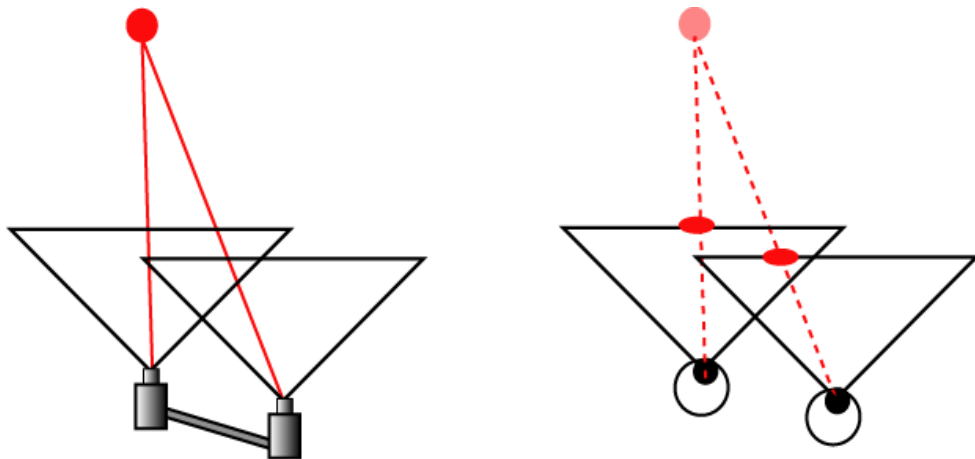

- 平行リンクにより, カメラが常に真正面を向いたまま回転
Parallel link moves the cameras while they always looks in front.

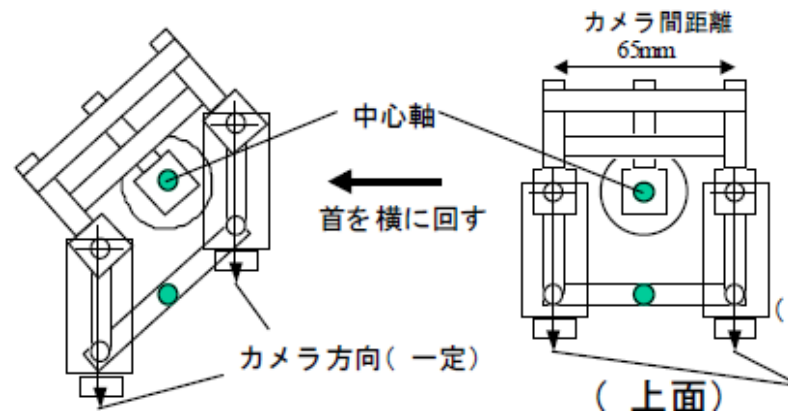

Virtual Screen

- Treat the Video stream in CG world.
- Put “virtual screen” on any place of the CG world.
- “Texture map” the video stream.
- Conversion of HMDcam to IPT is possible.

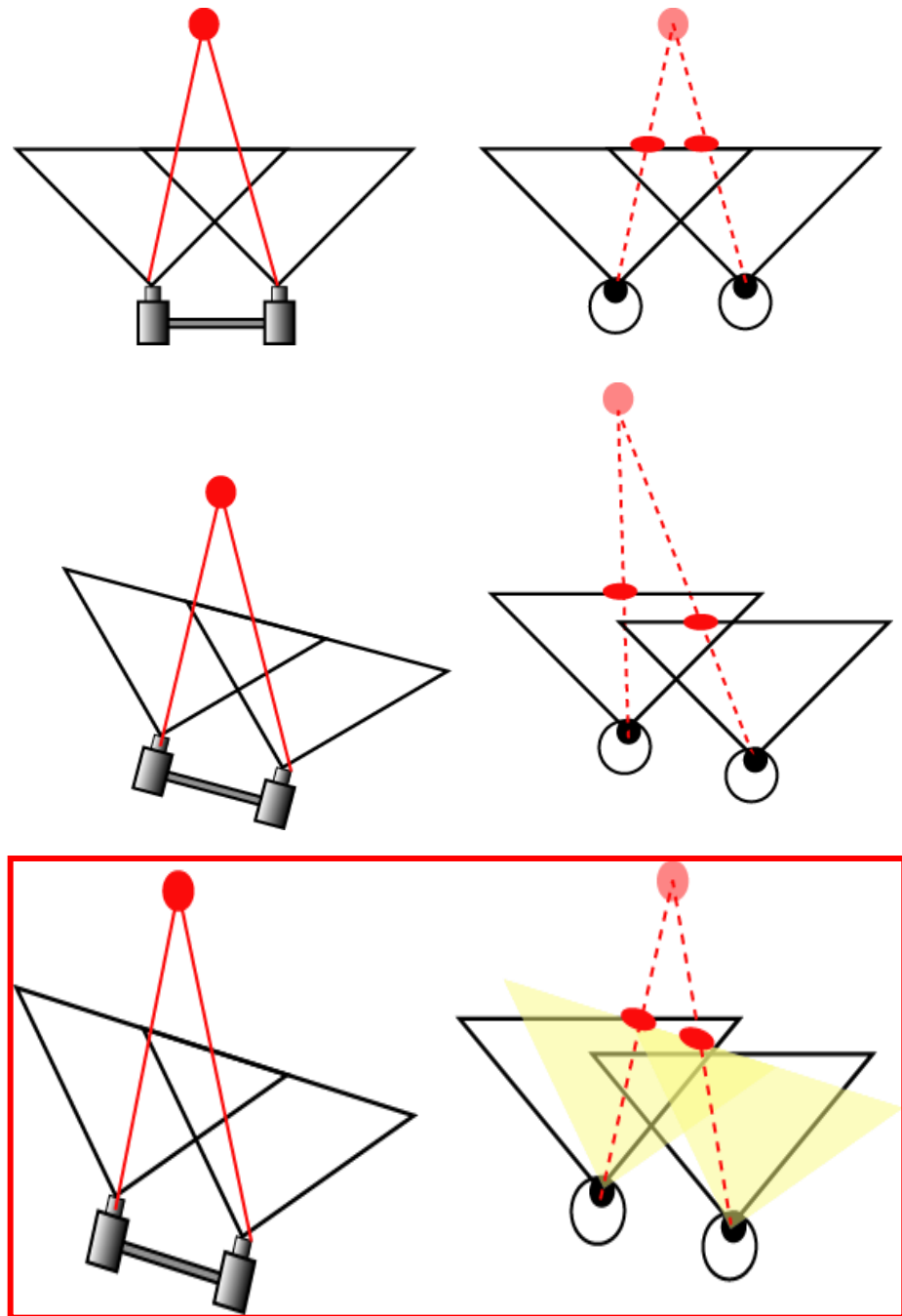

その他の注意点(2) 時間遅れの問題(再)

Other concerns(2) Time Latency(rep)

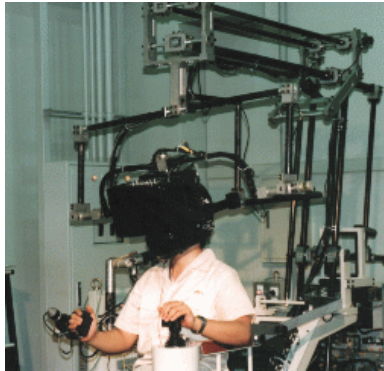

頭の動きの伝送
Head Motion

画像の伝送
Image transfer

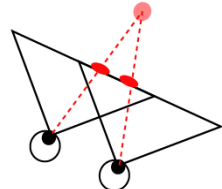
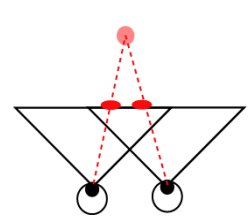
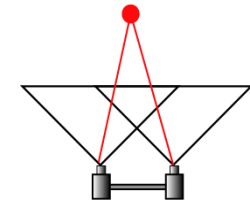
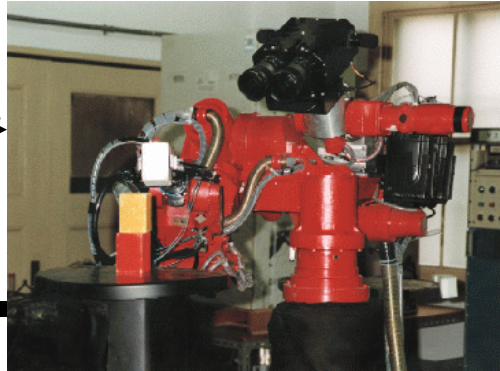

Time

- 頭の動きから描画までに時間遅れ.
Latency between head motion and image display

- 首を振ったとき When the head rotates:

- HMD:

- 画像が首の回転に付いてくる
The image moves

- 設置型 Ground fixed display:

- 画像は付いてこない. しかし立体視に関しては狂い, 奥行き方向にひずみを生じる.
The image does not move, but distort.

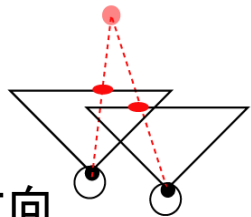
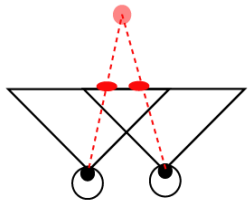
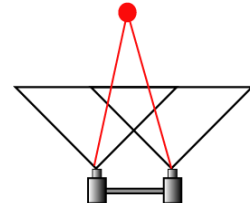

Time

TODAY'S TOPIC

- 3Dディスプレイ／3D Display
 - HMD
 - HMDとカメラ／HMD & Camera
 - HMDとAR／HMD & AR
 - 環境型／Environmental Display
 - メガネあり／With Eyeglasses
 - 環境型とカメラ／Environmental Display & Camera
 - メガネなし／Without Eyeglasses
 - 左右の目に違う映像を入れる／Input Different Images to Two Eyes
 - ボリュームメトリックな再構成／Volumetric Reconstruction
 - 光線群の制御による多視点映像／Ray Reconstruction
 - 錯覚を利用する／Using Illusion
- その他の話題
 - 光線群制御からCSCWへ／From Ray Control to CSCW
 - 光線群視点制御から視線制御へ／From Ray Control to Eye Control

Control Rays

Normal

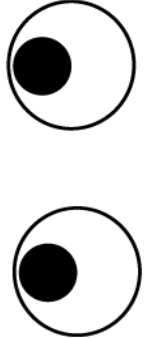
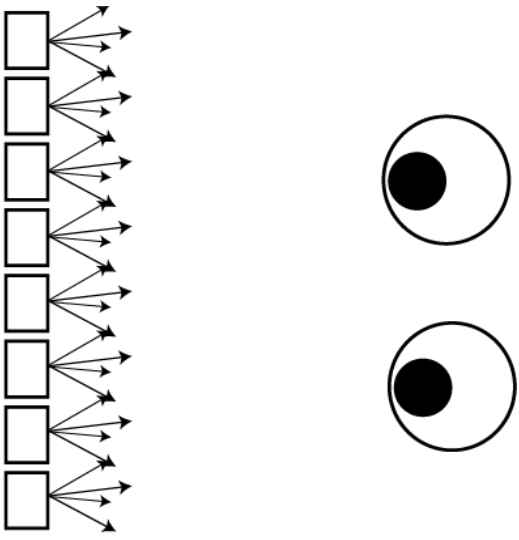

Lenticular

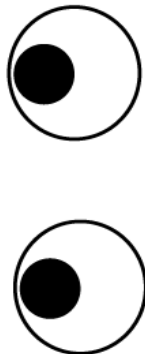
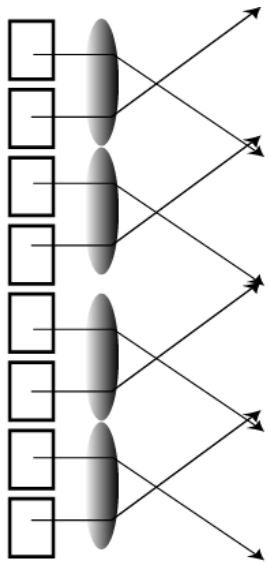

Parallax Barrier

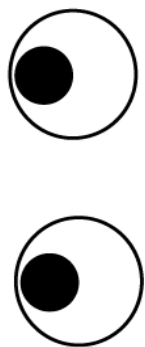
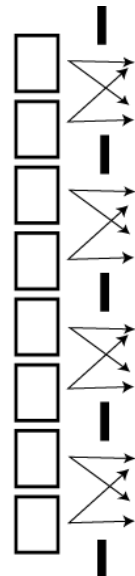

Pixels

Pixels

Pixels

- Put different rays to different direction
- No Eyeglasses!
- No Head tracking!
- Resolution is lowered



Y.Aono (2010)

www.nicovideo.jp/watch/sm12402466

裸眼3Dディスプレイを

自作してみた。

任天堂3DS

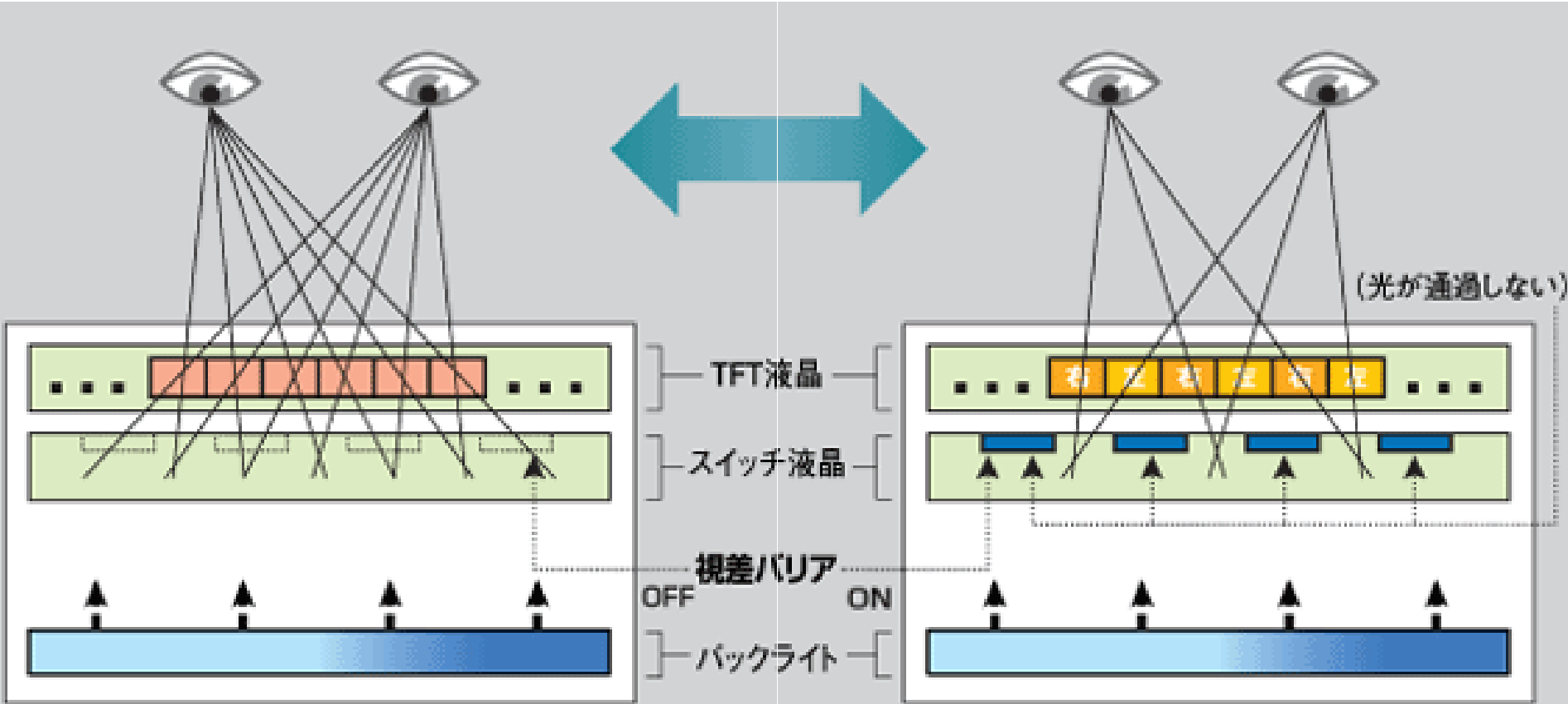

- バリア用の液晶層: 2D / 3D切り替え
LCD layer for parallax barrier: 2D/3D mode change
<http://www.sharp.co.jp/products/device/about/lcd/3d/index.html>

TWISTER: Use Moving Parallax Barrier

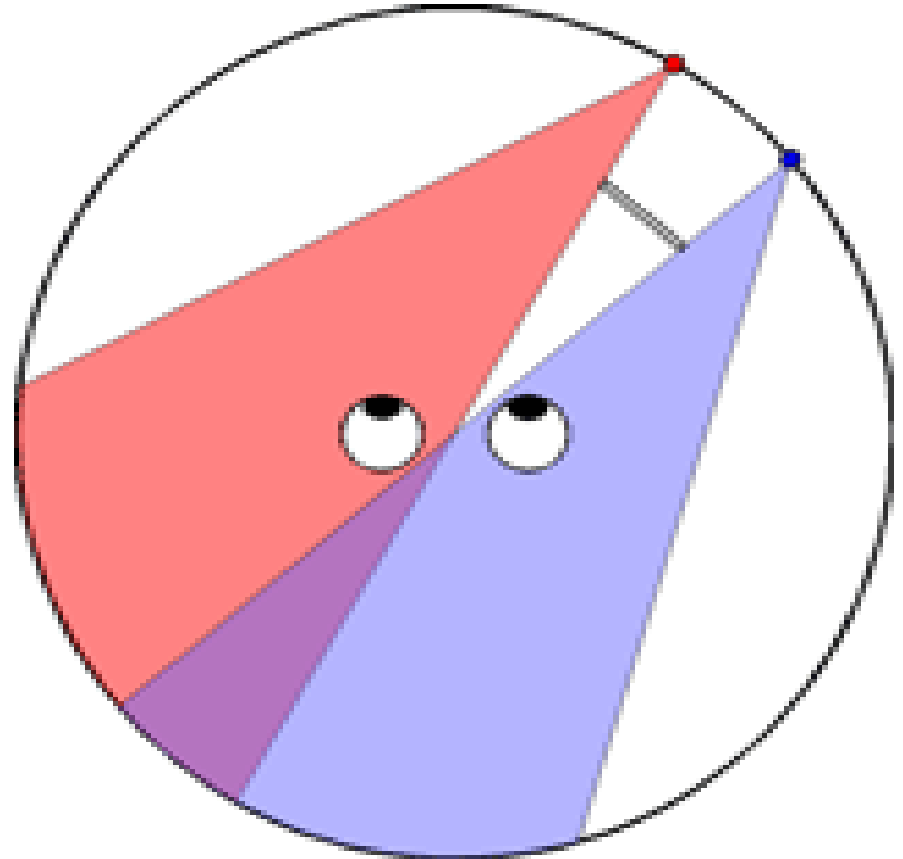
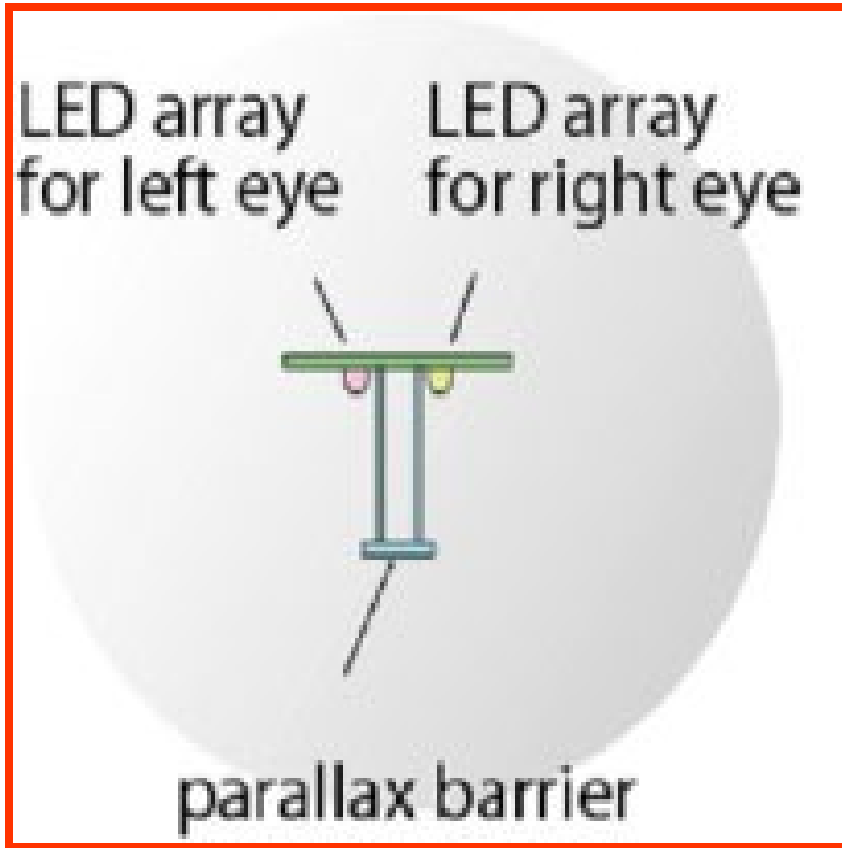

- Left and Right eye receive different LED light by the barrier.
- Rotates very fast, and the barrier “vanishes”

<http://projects.tachilab.org/TWISTER/>

TWISTER: Prototype



TWISTER-IV

http://www.youtube.com/user/tachilab#p/a/u/0/SX_IKm1rT4I

TODAY'S TOPIC

- 3Dディスプレイ／3D Display
 - HMD
 - HMDとカメラ／HMD & Camera
 - HMDとAR／HMD & AR
 - 環境型／Environmental Display
 - メガネあり／With Eyeglasses
 - 環境型とカメラ／Environmental Display & Camera
 - メガネなし／Without Eyeglasses
 - 左右の目に違う映像を入れる／Input Different Images to Two Eyes
 - ボリュームメトリックな再構成／Volumetric Reconstruction
 - 光線群の制御による多視点映像／Ray Reconstruction
 - 錯覚を利用する／Using Illusion
- その他の話題
 - 光線群制御からCSCWへ／From Ray Control to CSCW
 - 光線群視点制御から視線制御へ／From Ray Control to Eye Control

Volumetric Representation

- Rotate or vibrate the screen or mirror
- “Cross-section” image is projected according to the motion.

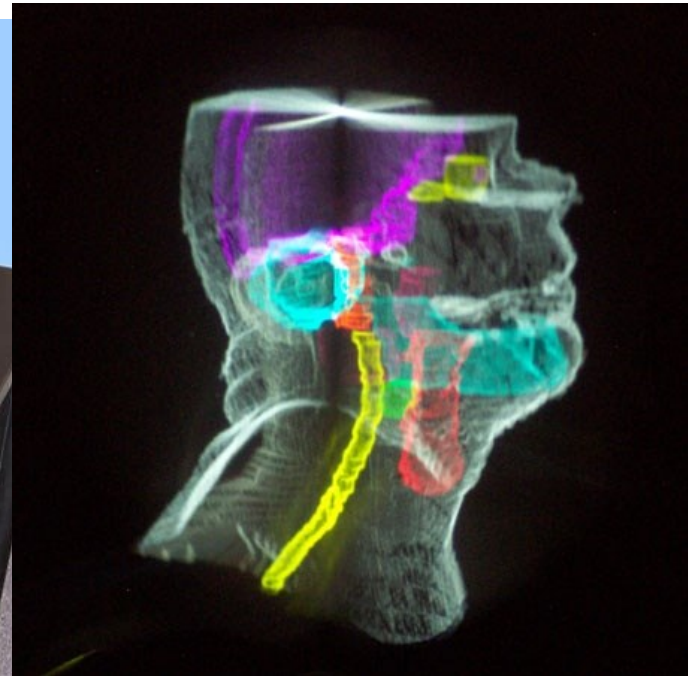
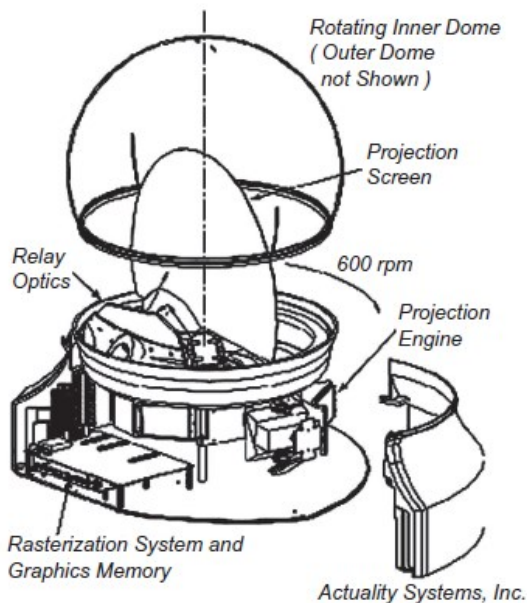



University of California
San Diego
Department of Biology
La Jolla, CA 92037



Volumetric representation by layered LCDs

- LightScape Technologies
DepthCube Z1024
- スクリーンの役割をする液晶スクヤットリング・シャッター20枚。DLPプロジェクターで背面投影。
20 LCD shutters are stacked as layered screen.
- 20枚の内、常に1枚だけシャッターが閉じる。高速にスクリーンが動くのと等価。
One shutter works at a time, equivalent to moving screen.

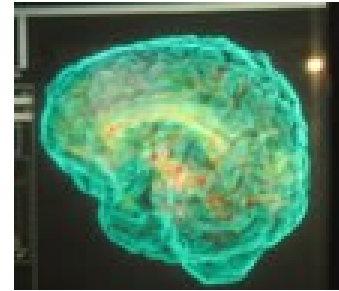

プラズマディスプレイ／Prasma display

- 赤外レーザービームを空間中にフォーカスし、空気をプラズマ化して発光させる Focused IR Laser beam generates prasma light spot

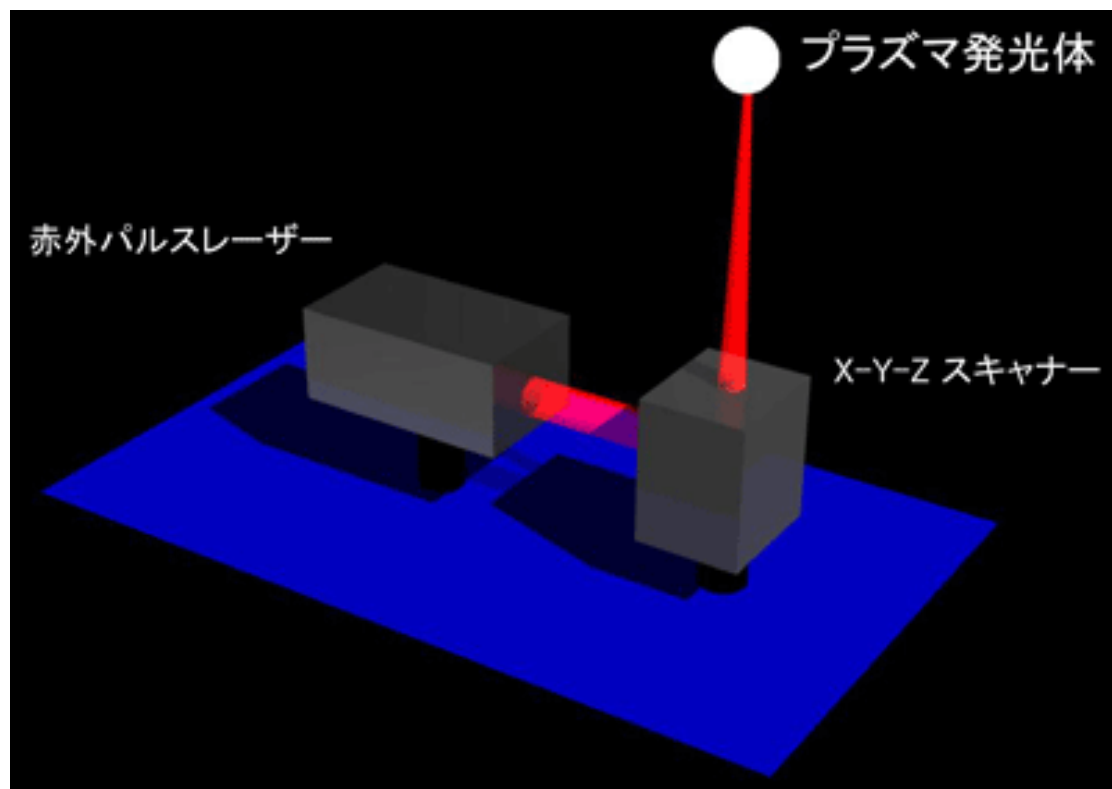
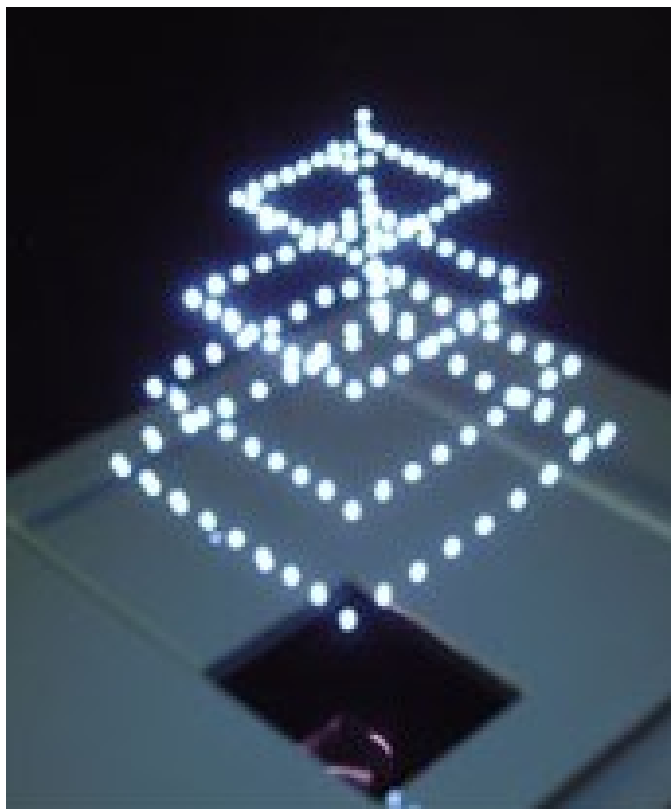



- ミラー＋振動子による3次元像をフロントガラスで自動車の外に飛ばす
- 実際に虚像が生じるので頭部位置に依存しない

Virtual Cable <http://www.mvs.net/>

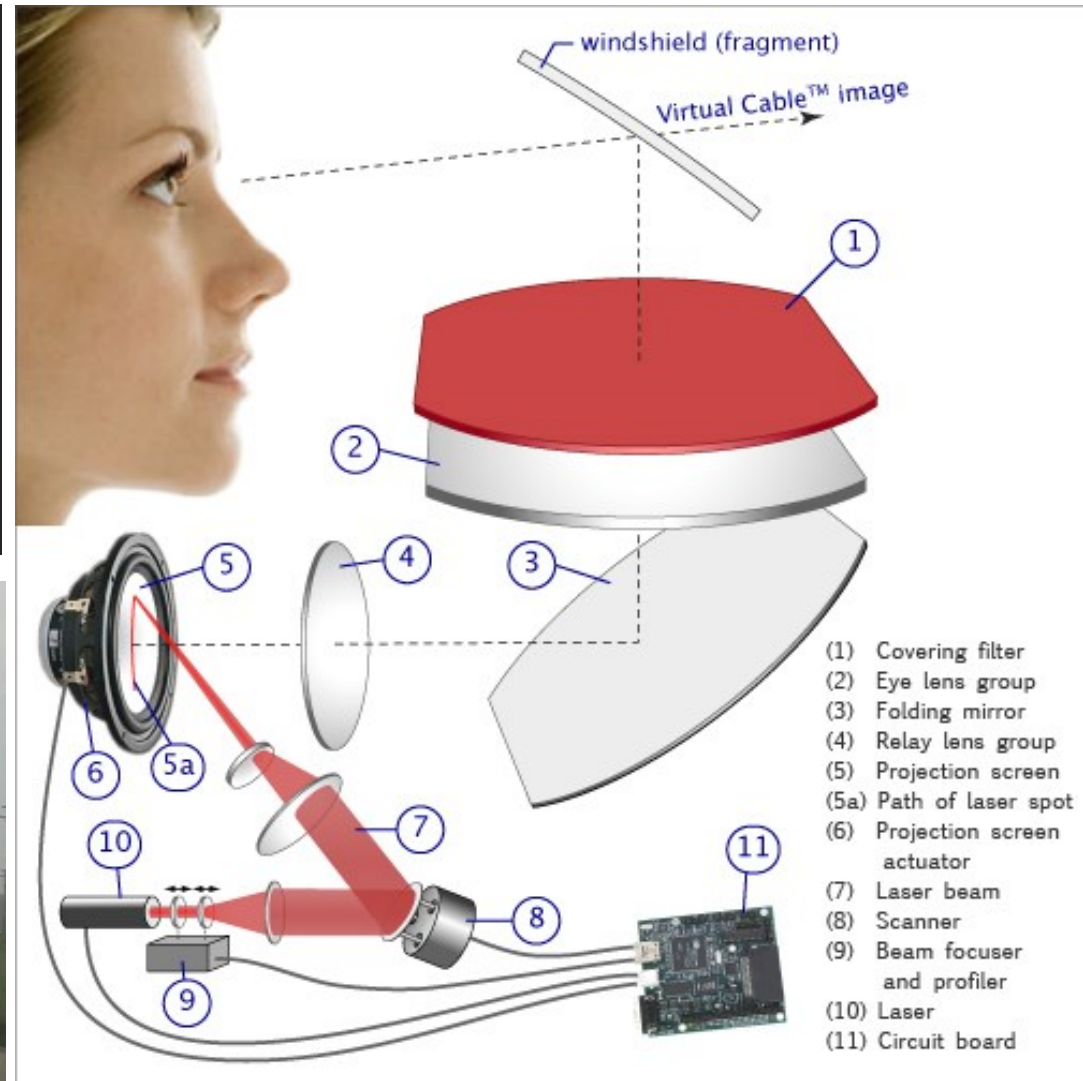
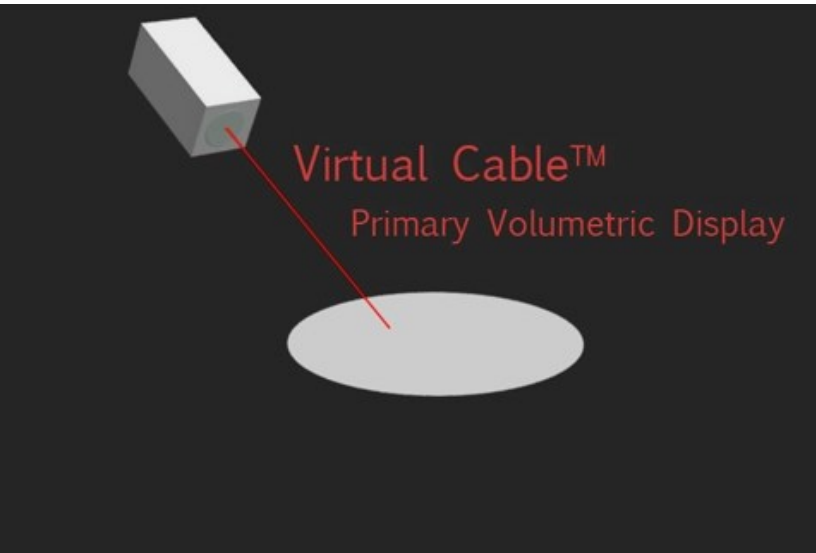

Fig. 3 Hardware components the Virtual Cable™ display (illustration)

パイオニアのAR HUD

http://www.youtube.com/watch?v=koEyBO_RxZE&feature=player_embedded

TODAY'S TOPIC

- 3Dディスプレイ／3D Display
 - HMD
 - HMDとカメラ／HMD & Camera
 - HMDとAR／HMD & AR
 - 環境型／Environmental Display
 - メガネあり／With Eyeglasses
 - 環境型とカメラ／Environmental Display & Camera
 - メガネなし／Without Eyeglasses
 - 左右の目に違う映像を入れる／Input Different Images to Two Eyes
 - ボリュームメトリックな再構成／Volumetric Reconstruction
 - 光線群の制御による多視点映像／Ray Reconstruction
 - 錯覚を利用する／Using Illusion
- その他の話題
 - 光線群制御からCSCWへ／From Ray Control to CSCW
 - 光線群視点制御から視線制御へ／From Ray Control to Eye Control

レンズアレイ方式 / Using lens array

- レンチキュラーレンズを2次元に拡張
gCubik (Yoshida et al.(NICT), SIGGRAPH2008)

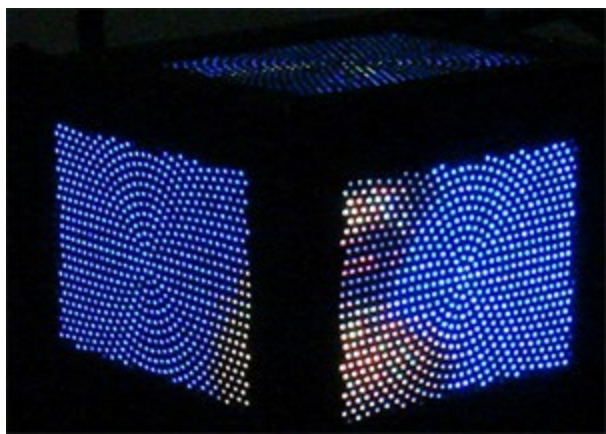
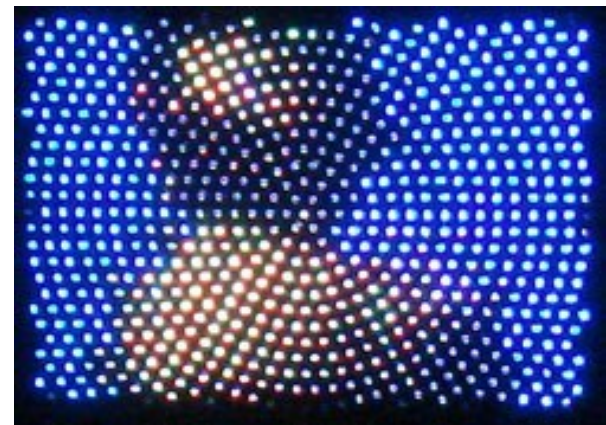
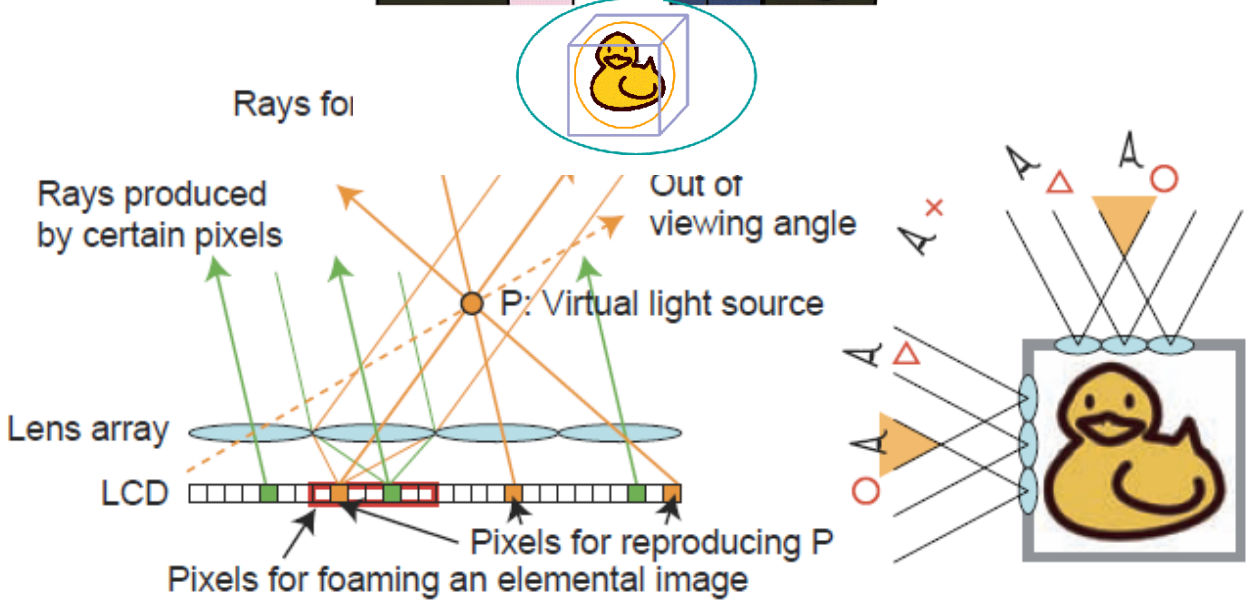

gCubik (Yoshida et al)

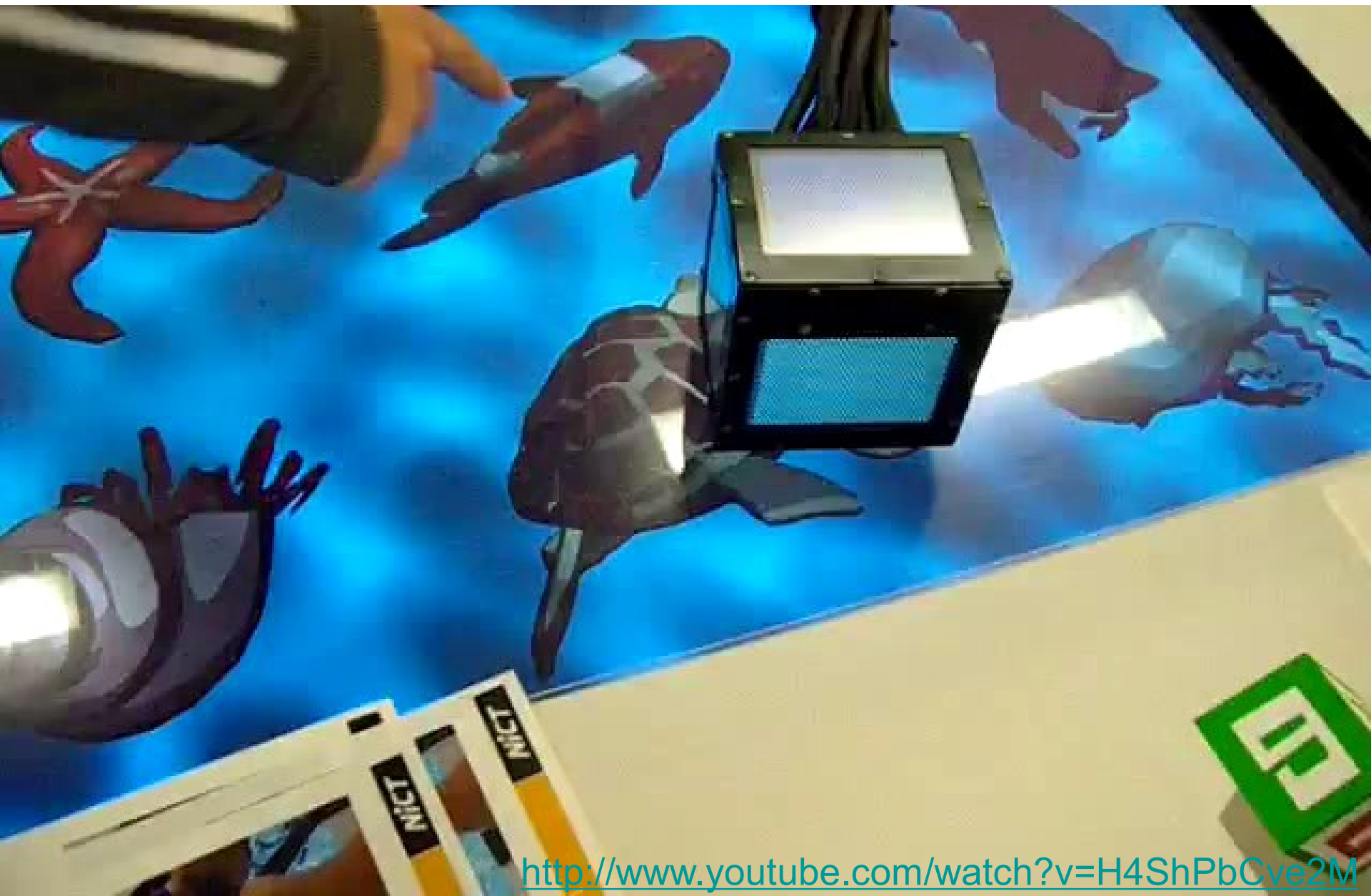

再帰性反射材を用いた全周囲回転型3D ディスプレイ (日立、2004) / Rotational 3D display using Retroreflector

- 回転スクリーンに、各角度から見た映像を投影
Images from different direction is projected on rotational screen.
- スクリーンは水平方向のみ再帰性反射特性を持つ(この特性がないと絵が「混ざる」)
Screen is retroreflective only for horizontal direction

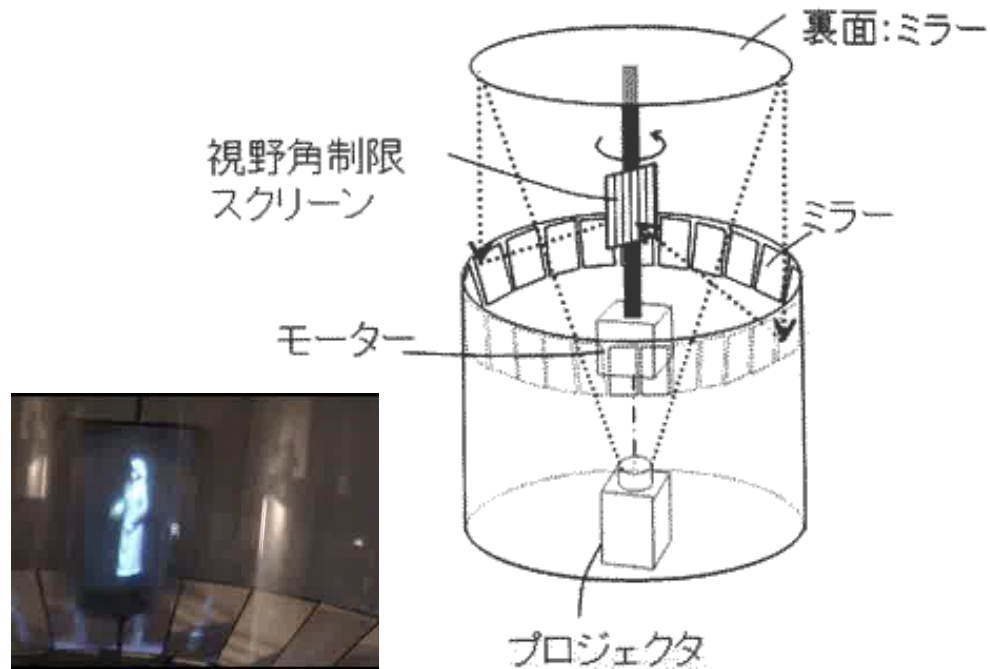
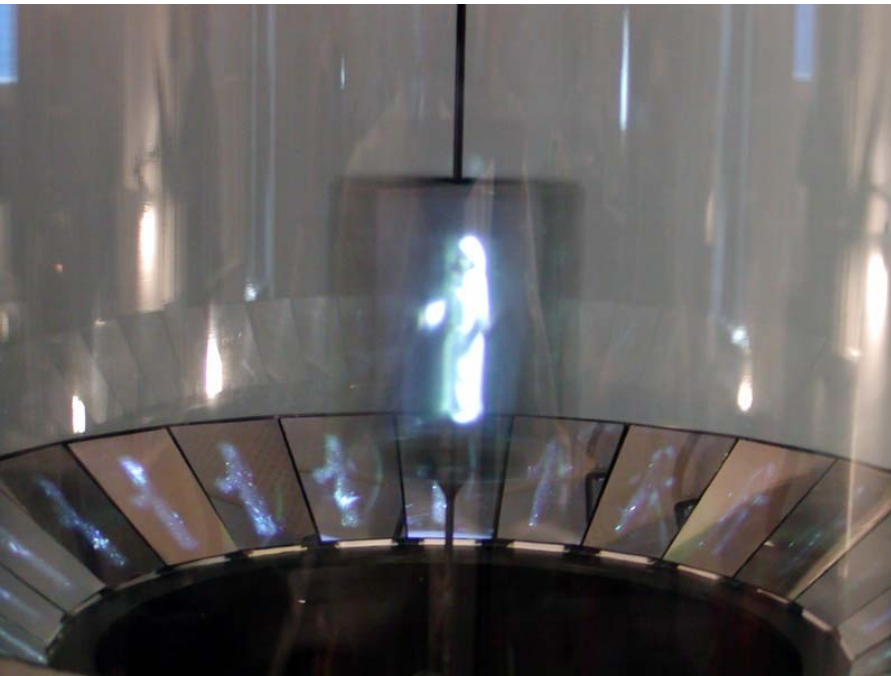

RePro3D (T. Yoshida et al. 2010)

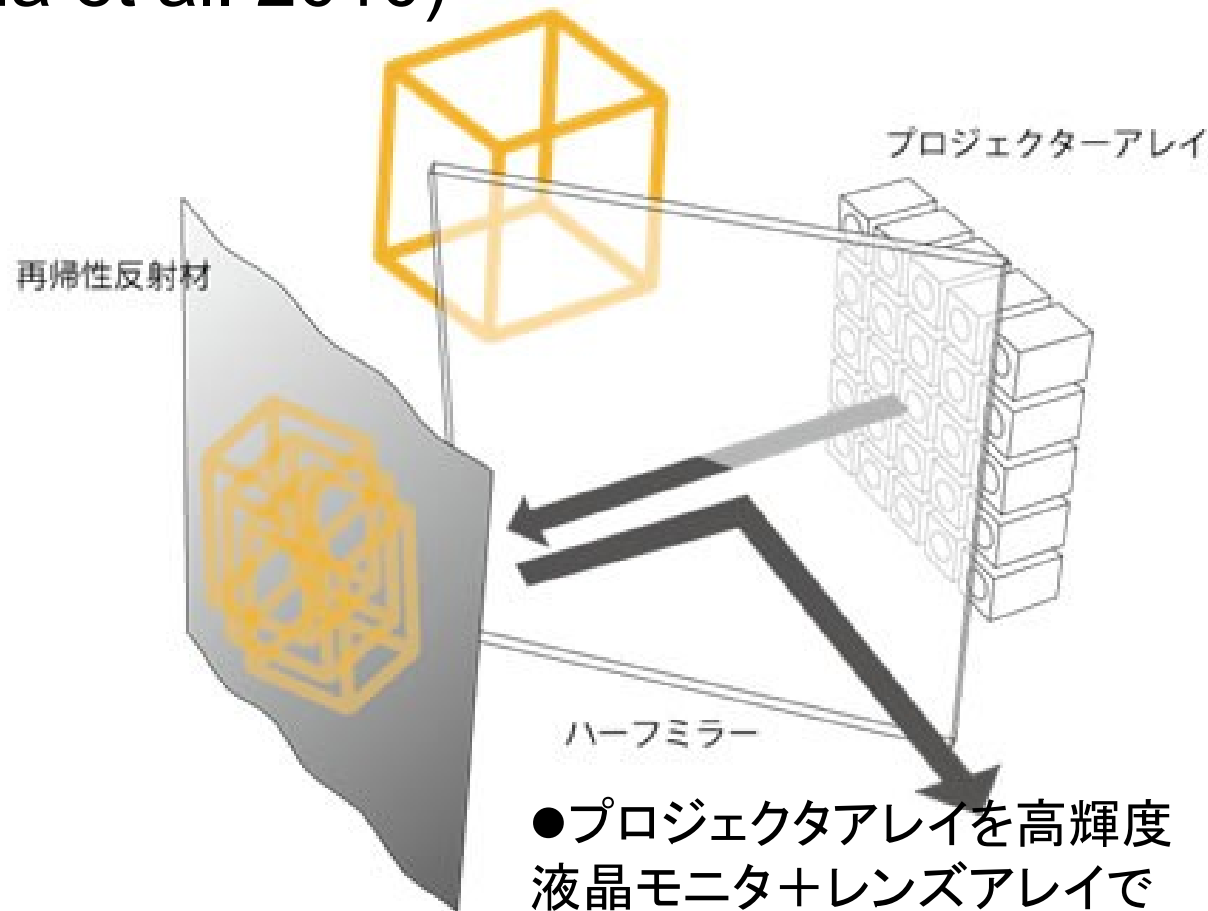

- プロジェクターアレイを高輝度液晶モニター+レンズアレイで擬似的に構成

- 再帰性反射材による多視点の実現

Projector array and retroreflector generate eye position dependent images.



RePro3D (T. Yoshida et al. 2010)

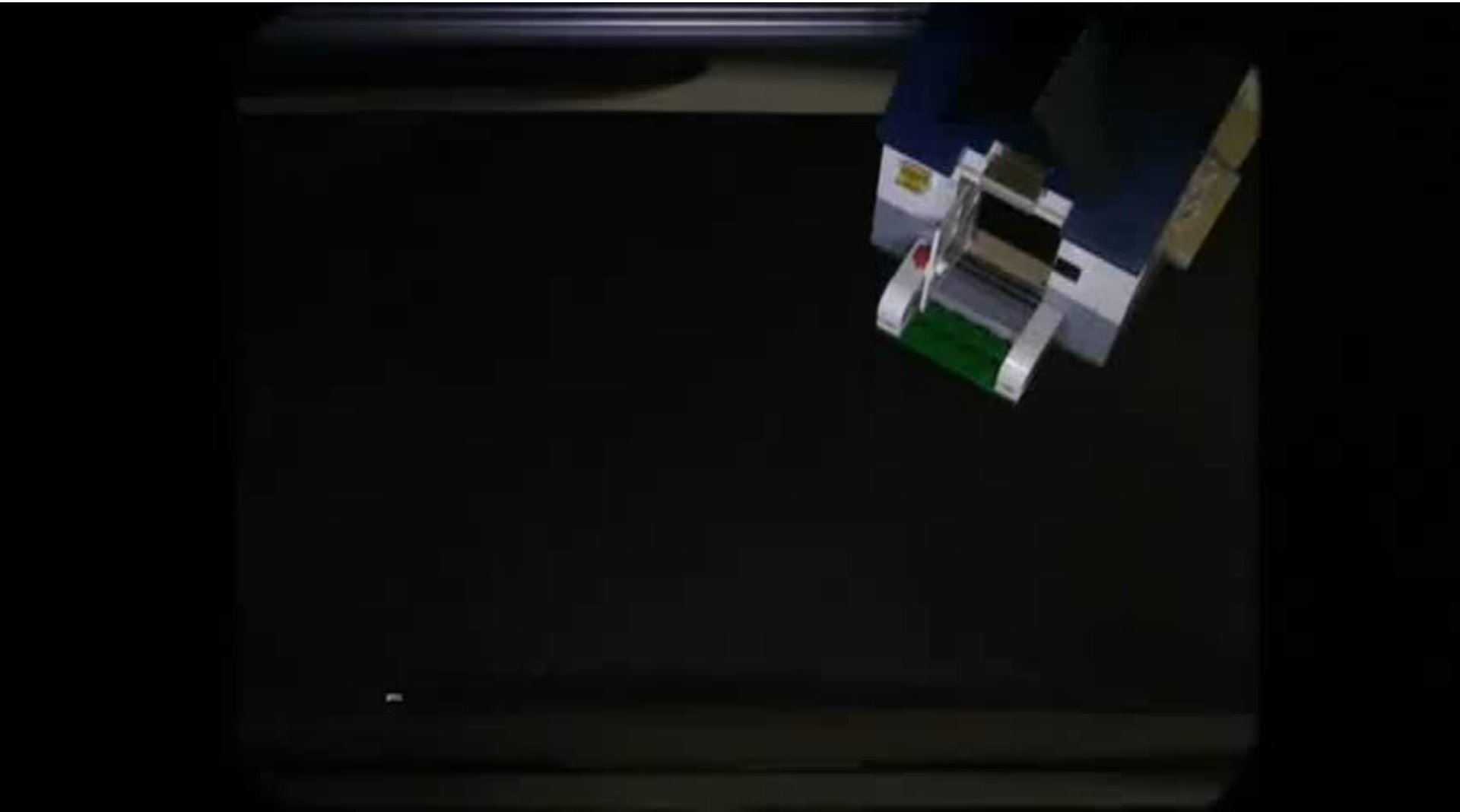

<http://www.youtube.com/watch?v=8TbSBYiwZIs>

SeeLinder (Yendo et al., 2005)

Using the parallax barrier in a different manner

LED arrays move relatively slow

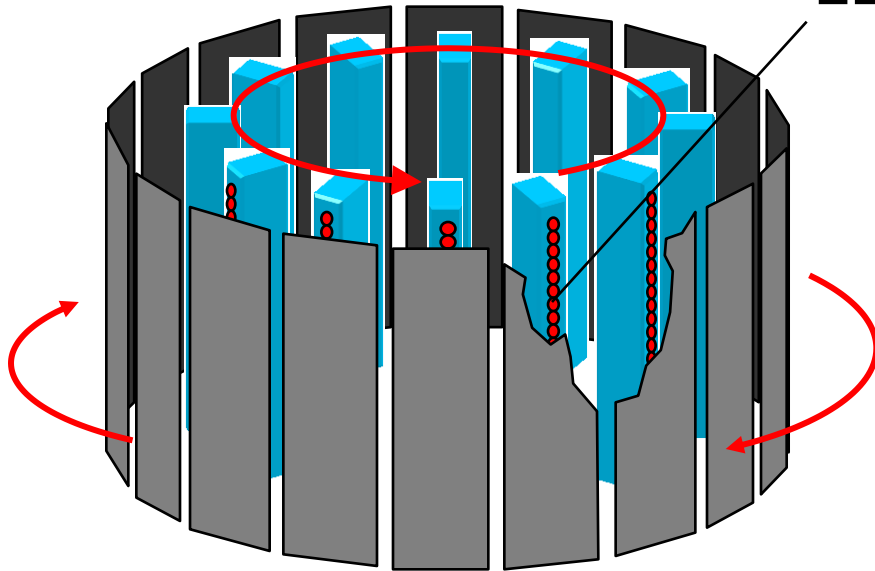

Barrier moves VERY fast

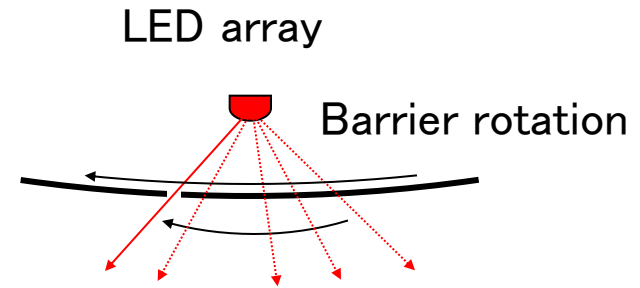

According to the barrier rotation, LED changes is luminance.

Omni-directional rays are constructed

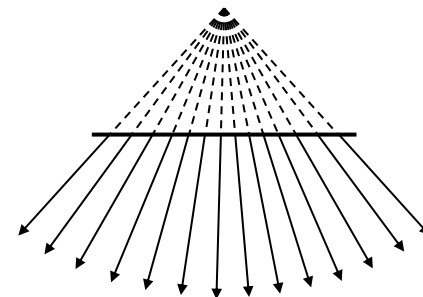

SeeLinder (Yendo et al., 2005)



<http://tachilab.org/modules/projects/seelinder.html>

-Rendering for an Interactive 360° Light Field Display

-HeadSPIN (A. Jones, 2007, 2009)

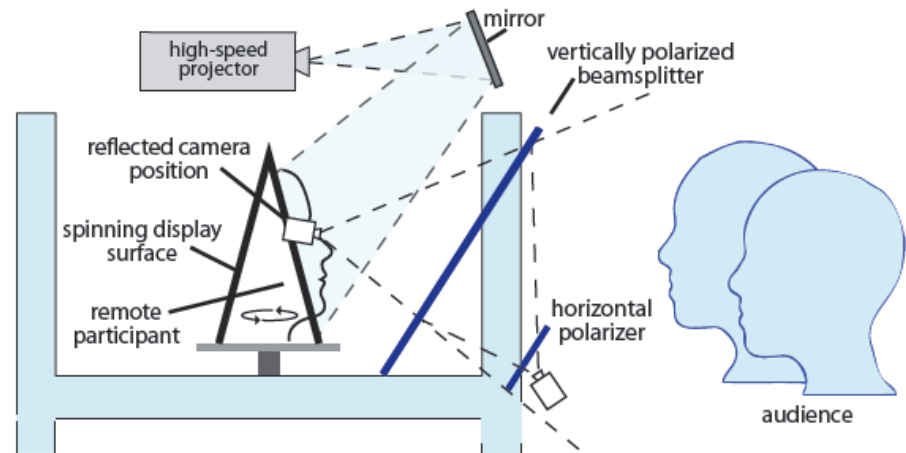
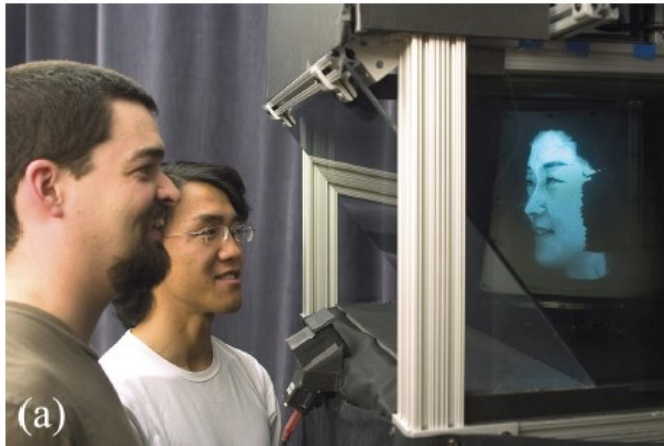
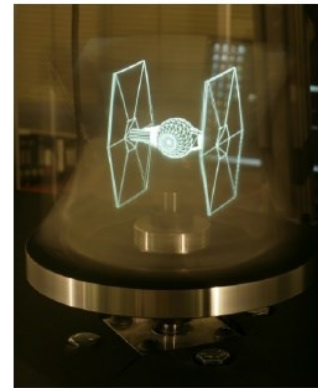
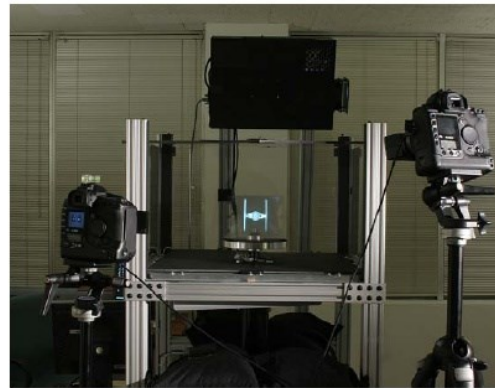
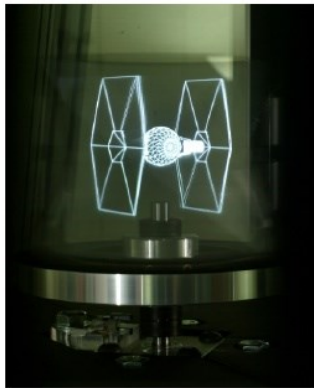
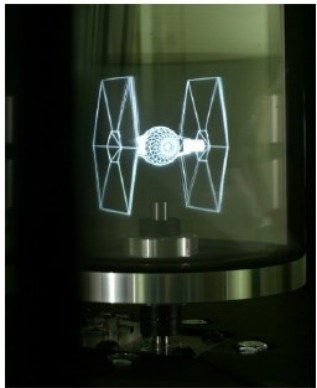

回転ミラー表面にホログラフィックフィルム。垂直方向に拡散、水平方向は鏡面反射→ミラーの正面からしか映像が見えない

Rotational mirror has holographic film, enabling vertical diffusion and horizontal reflection

HeadSPIN (A. Jones et al., SIGGRAPH2009)



<http://vimeo.com/5812643>

8D (A. Jones et al., CHI2013)

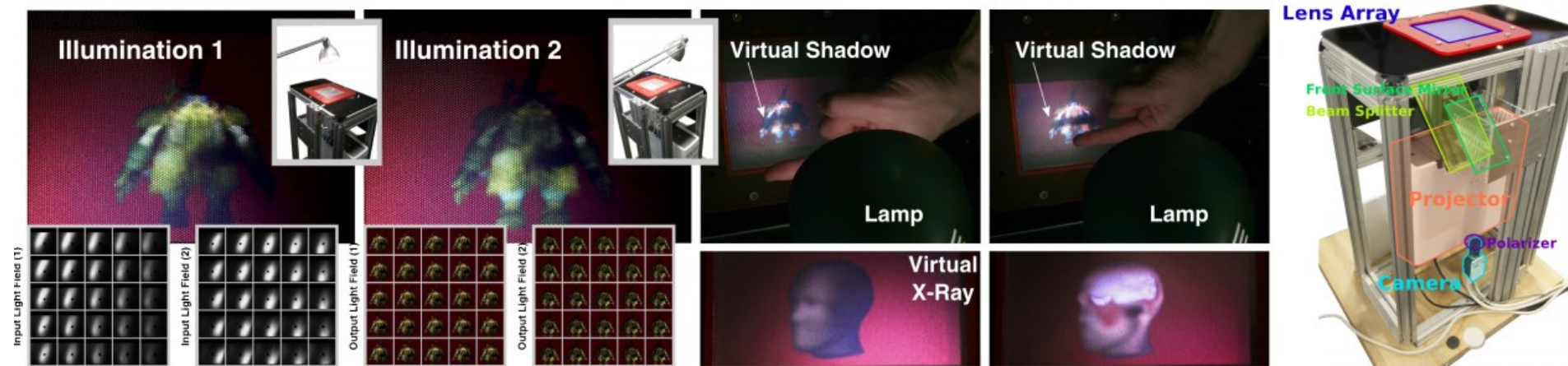

Figure 1. The 8D prototype allows for glasses-free display of 3D content, whilst simultaneously capturing any incident light for re-illumination and interaction. From left to right: A user shines a light source (lamp) at the 3D display, and the rendered 3D model is correctly re-illuminated. Virtual shadows can be cast by placing a finger between the display and light source. This allows any light source to act as an input controller, for example to allow intuitive interaction with a medical data set. 8D works by simultaneously capturing and displaying a 4D light field (as shown bottom left inset).

微小レンズアレイによる光線群再構成を逆向きにも使用し、外部の光線環境を取得。

Hirsch et al.: 8D: Interacting with a Relightable Glasses-Free 3D Display, CHI2013

<http://web.media.mit.edu/~mhirsch/8D/>

TODAY'S TOPIC

- 3Dディスプレイ／3D Display
 - HMD
 - HMDとカメラ／HMD & Camera
 - HMDとAR／HMD & AR
 - 環境型／Environmental Display
 - メガネあり／With Eyeglasses
 - 環境型とカメラ／Environmental Display & Camera
 - メガネなし／Without Eyeglasses
 - 左右の目に違う映像を入れる／Input Different Images to Two Eyes
 - ボリュームメトリックな再構成／Volumetric Reconstruction
 - 光線群の制御による多視点映像／Ray Reconstruction
 - 錯覚を利用する／Using Illusion
- その他の話題
 - 光線群制御からCSCWへ／From Ray Control to CSCW
 - 光線群視点制御から視線制御へ／From Ray Control to Eye Control

3Dディスプレイは必要か

Is 3D display really necessary?

- Maybe, but not for all works
 - Yet too expensive, and contents are limited.
 - To “observe” something, resolution is more important than 3D. (You can observe with single eye!)
- However,
 - To handwork in a virtual space, “distance” perception between myself and the CG object is critically important.

空中像による錯覚／Illusion by floating image

- 空中に(他の支えが無く)映像が浮いている場合、人は勝手に「立体的」と判断する

When the image is floating in the air without anchorage, we feel it as 3D



Fog Screen

<http://www.fogscreen.com/>



フローティングビジョン Floating Vision (パイオニア, 2008)

一つの凸レンズにより結像した実像を観察
glasses-free small 3-D display basic structure test.

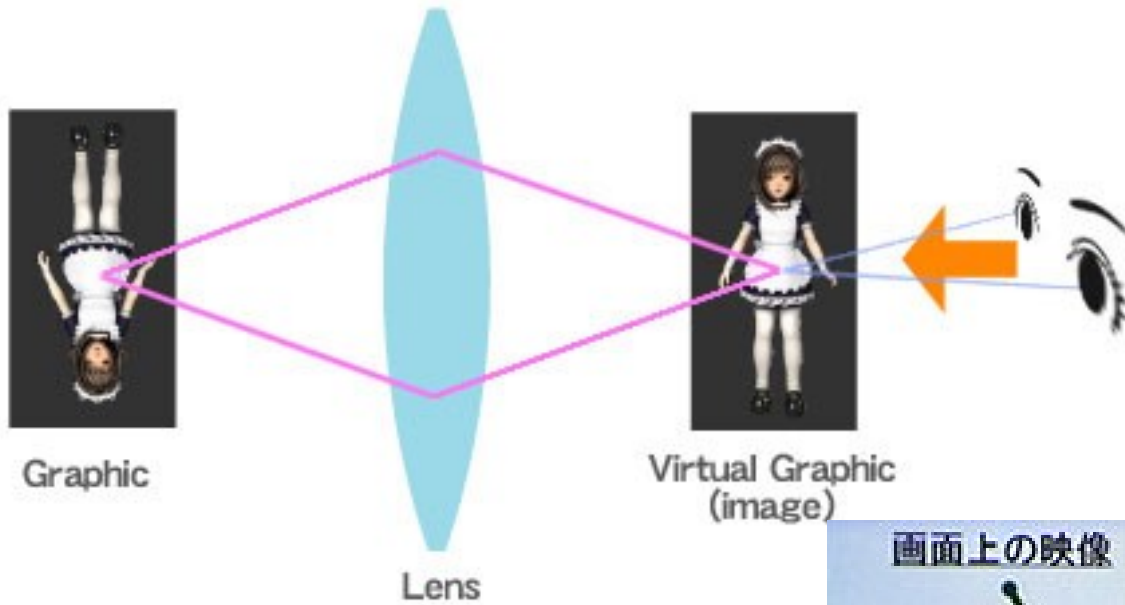

<http://www.schaft.net/n00bs/2010/02/24230148.html>

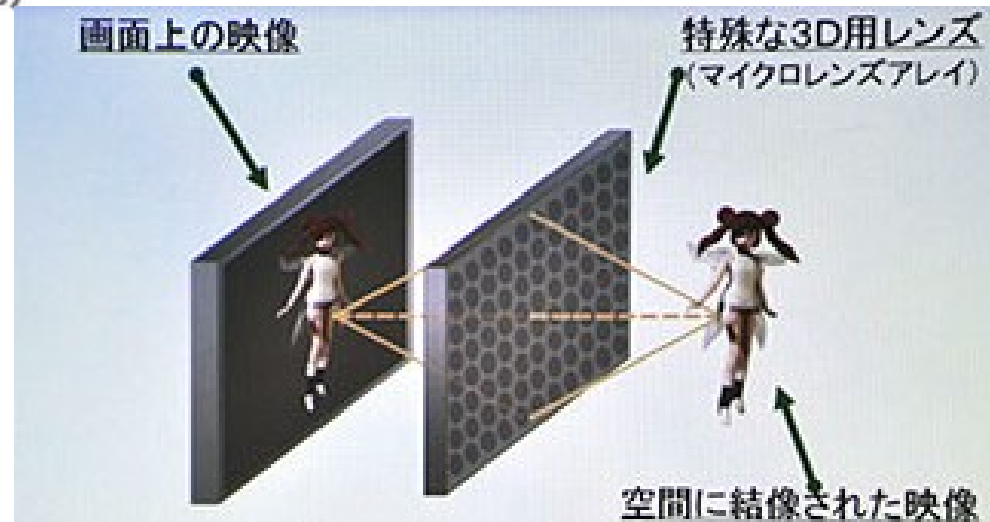

フローティングビジョン(パイオニア,2008)



http://www.youtube.com/watch?v=Wzx9zid_FoA

プルフリッチ効果／Pulfrich Effect

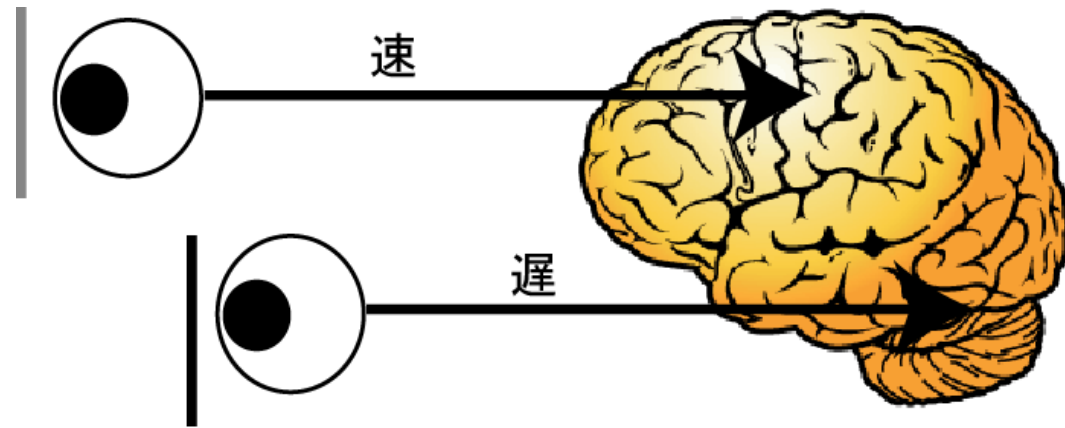

- 両目の濃度が違うサングラスをかけて見る
Put eyeglasses with two different darkness for each eye
- 明るさの違いによって脳への視覚情報伝達に**時間差**を生じる。
Different brightness generates temporal difference
- **動画の横の動き**によって視差が生じ、奥行きが体感される
Horizontal motion of the movie causes disparity, generates 3D feeling

というわけで

ニコニコ動画のコメントを 立体視で浮かせてみた

「ニコニコ動画のコメントを立体視で浮かせてみた」

http://blog.mobilehackerz.jp/2010/02/blog-post_17.html

立体錯視現象／Pseudo 3D by 2 stacked images

- NTT:Spacellusion

- DFD方式: 明るさの異なる同一の二枚の画像を重ねて表示すると、奥行き感を感じられる(視覚的なPhantom Sensation?)

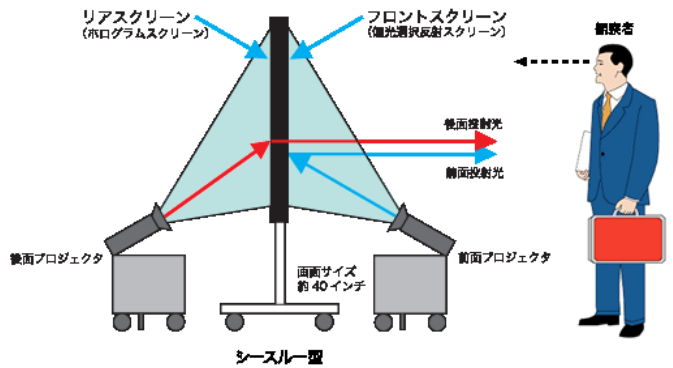
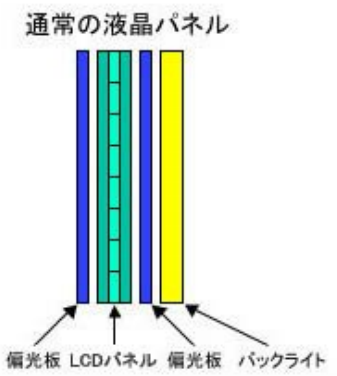
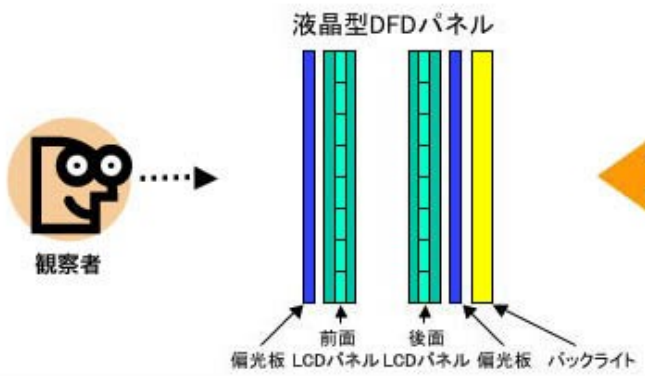
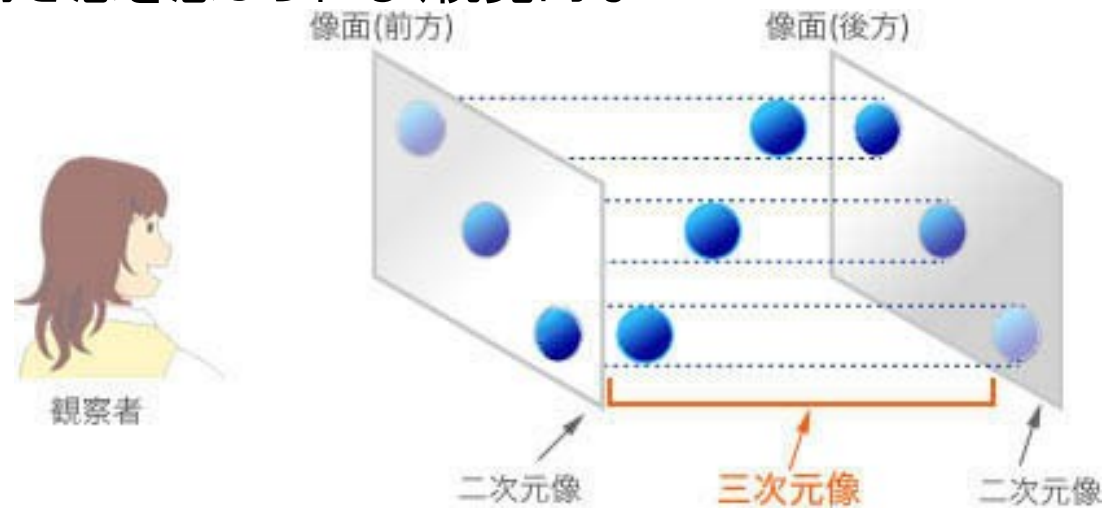

運動視差を用いる／Using Motion Parallax



- 視点位置に合わせて画像を変化させると、両眼立体視をしていなくても奥行き感を明瞭に感じる

i3D Head tracking for iPad

http://www.youtube.com/watch?feature=player_embedded&v=bBQQEcfkHoE

2010年7月2日金曜日

0:31:19

3Dのように見えるiPhoneアプリを作ってみました

http://www.youtube.com/watch?v=k07VmPeY2-U&feature=youtube_gdata_player

TODAY'S TOPIC

- 3Dディスプレイ／3D Display
 - HMD
 - HMDとカメラ／HMD & Camera
 - HMDとAR／HMD & AR
 - 環境型／Environmental Display
 - メガネあり／With Eyeglasses
 - 環境型とカメラ／Environmental Display & Camera
 - メガネなし／Without Eyeglasses
 - 左右の目に違う映像を入れる／Input Different Images to Two Eyes
 - ボリュームメトリックな再構成／Volumetric Reconstruction
 - 光線群の制御による多視点映像／Ray Reconstruction
 - 錯覚を利用する／Using Illusion
- その他の話題
 - 光線群制御からCSCWへ／From Ray Control to CSCW
 - 光線群視点制御から視線制御へ／From Ray Control to Eye Control

Illusion Hole (Kitamura et al., 2001)

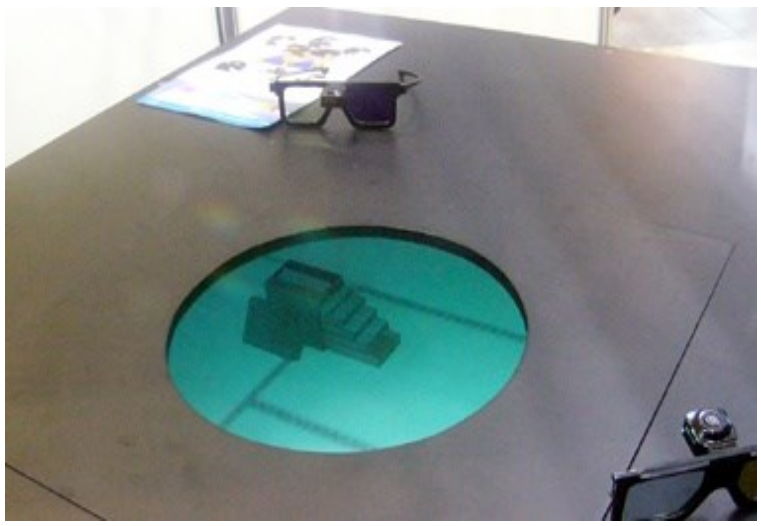
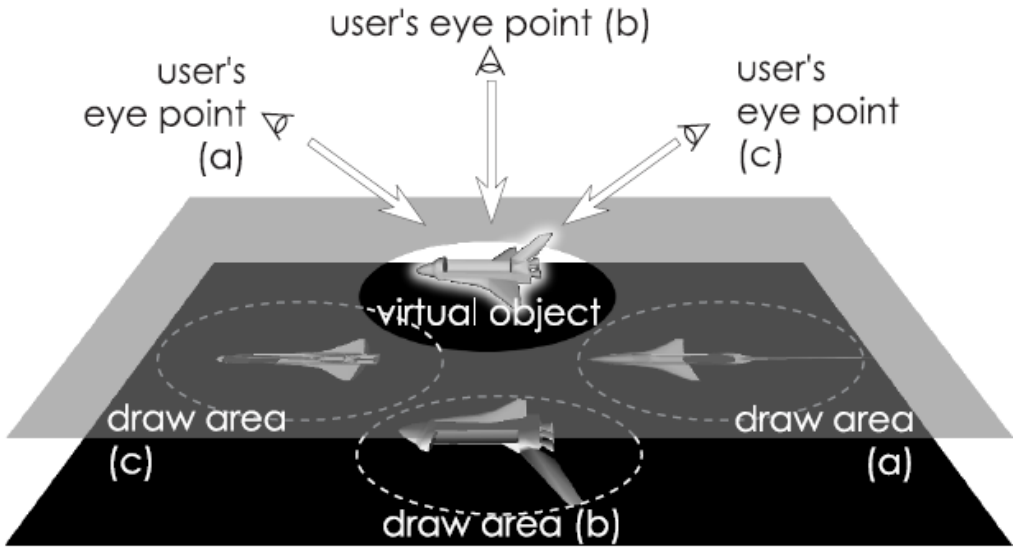
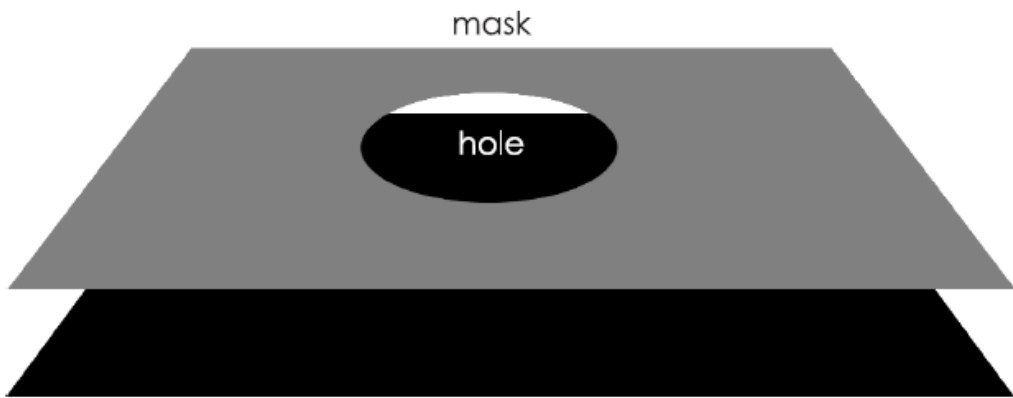

Illusion Hole (Kitamura et al., 2001)

Lumisight Table (Kakehi et al., 2003)

- 住友化学の建築素材ルミスティ: 視線の角度に応じて視界が「すりガラス」のようにぼやけて見えるようになる光学フィルタフィルム。
- Light control film “Lumisty”: works both as diffuser and transparent film for different angle.

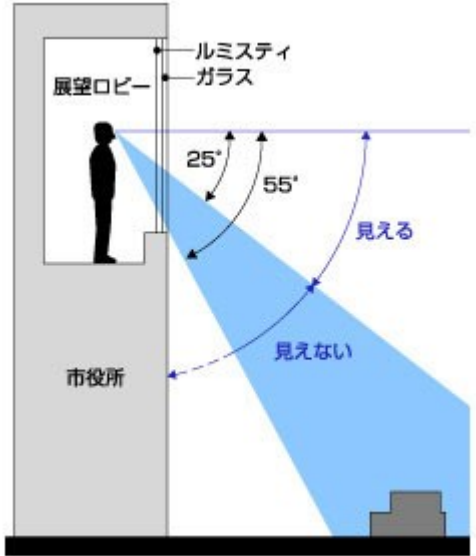

Lumisight Table (Kakehi et al., 2003)

- 4人が別々の映像を観察
Different images for different user
- 透明性を利用して手の動きを測定
Simultaneous motion analysis is possible using transparency

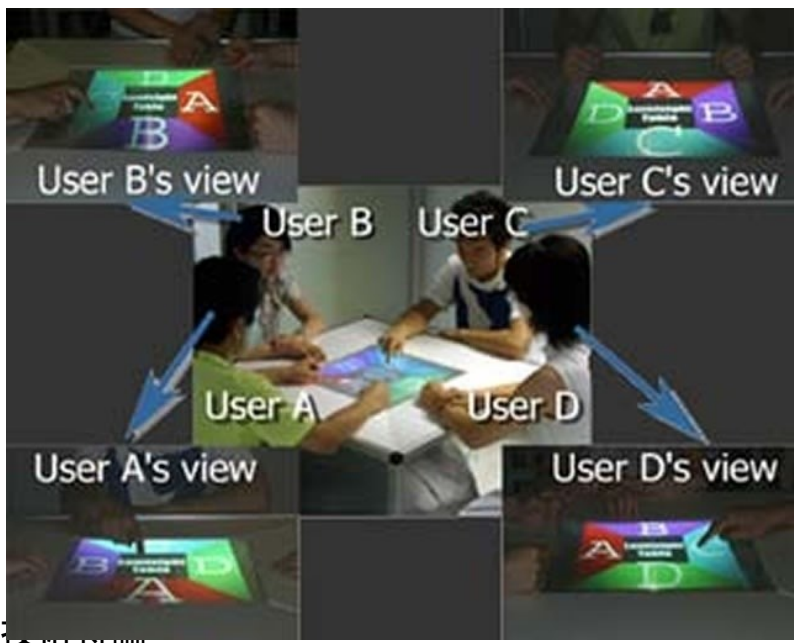
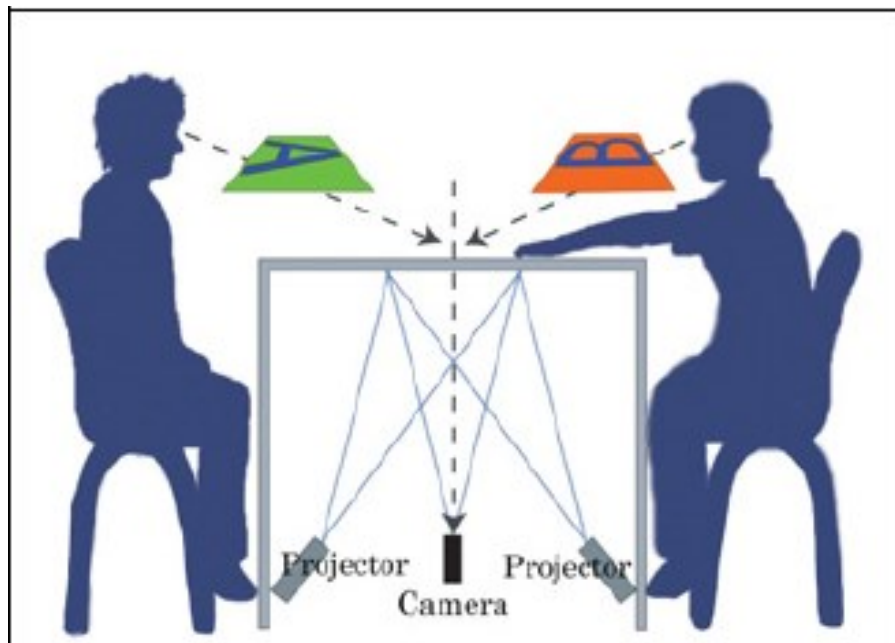
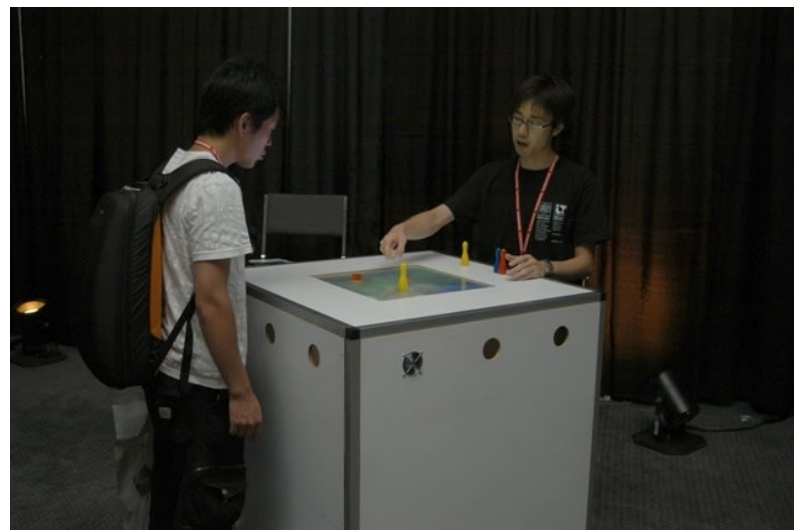

TODAY'S TOPIC

- 3Dディスプレイ／3D Display
 - HMD
 - HMDとカメラ／HMD & Camera
 - HMDとAR／HMD & AR
 - 環境型／Environmental Display
 - メガネあり／With Eyeglasses
 - 環境型とカメラ／Environmental Display & Camera
 - メガネなし／Without Eyeglasses
 - 左右の目に違う映像を入れる／Input Different Images to Two Eyes
 - ボリュームメトリックな再構成／Volumetric Reconstruction
 - 光線群の制御による多視点映像／Ray Reconstruction
 - 錯覚を利用する／Using Illusion
- その他の話題
 - 光線群制御からCSCWへ／From Ray Control to CSCW
 - 光線群視点制御から視線制御へ／From Ray Control to Eye Control

眼球運動の利用／Using eye movement

- 2種類の眼球運動

- Smooth Pursuit(滑動性追跡眼球運動)

ゆっくりと動く小さな点を追跡する随意性の眼球運動.

- Saccade(跳躍性眼球運動)

ステップ上の眼球運動. 不随意.

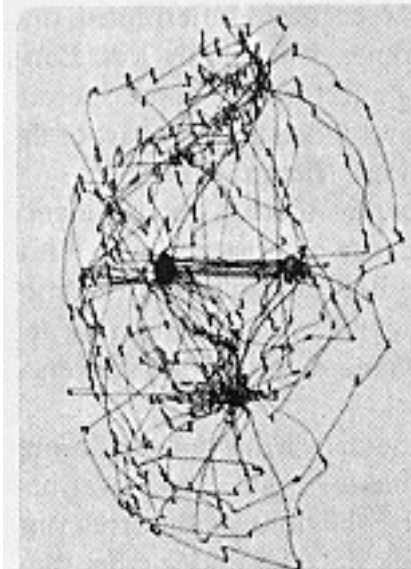

スムーズパーサートの利用／Using Smooth pursuit ポールビジョン技術とは

照明用光源などとして普及が著しいLED。ポールビジョンでは3色(光の3原色である赤・青・緑)の超高輝度タイプを採用していますので、文字や画像を鮮やかに表現できます。

通常の電光掲示板1

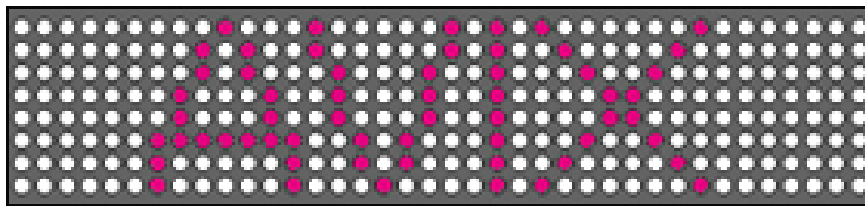

通常の電光掲示板2

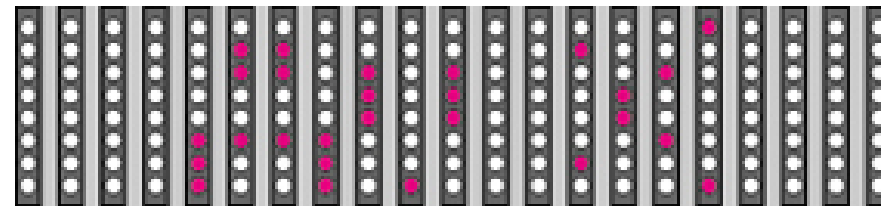

ただこれだけでまどんな映像が表示されているのかわかりません。そこで、左右どちらか一方に映像をスクロールさせることによって、間引かれている部分に残像を起こし映像を表示させているのです。

[ポールビジョン]

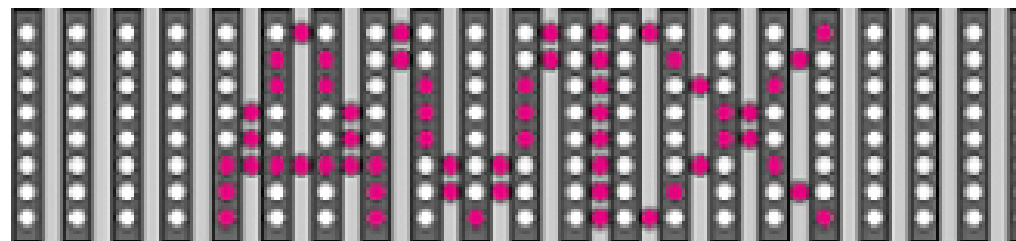

←スクロール

このように残像技術を用いることで、使用する部品数を極端に減らしてコストを抑えることができます。

http://www.avix.co.jp/service/billboard/pole_vision/index02.html

アビックス(株)ポールビジョン



<http://www.youtube.com/watch?v=KhpMzNYetis>

Saccade Based Display (Watanabe et al)

- サッケード: 瞬間的に大きく跳躍する
- その瞬間に網膜に書き込むことで, 一本のLED列で画像を提示できる

– (体験できる場所: お台場メディアージュ5F・ソニーエクスプローラサイエンス)
Present image at the instance of saccadic eye movement, using linear LED array

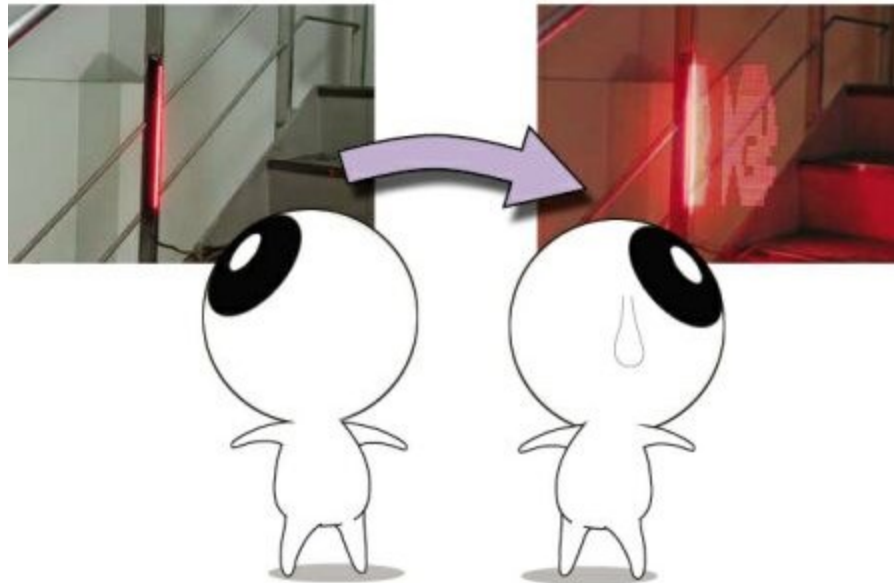

Saccade Based Display (Watanabe et al.)

http://www.youtube.com/watch?v=d_pjvSt3w18

小テスト／Mini Test 次回開始まで

以下の全てに100字以内程度で解答せよ／Answer all questions within 50 words

1. HMDの基礎的な光学系における凸レンズの役割について説明せよ
Explain the role of convex lens in HMD.
2. ARを実現するHMDの代表的な二つの方式をなんと呼ぶか
What are two types of HMD for AR?
3. ARにおける焦点調節の問題について説明せよ
Explain problem related to focal distance in AR system
4. ARにおける遮蔽問題について説明せよ
Explain problem related to occlusion in AR system.
5. 波長フィルタを用いた両眼立体視でフルカラーを実現する方法について説明せよ
Explain how to realize full-color stereoscopic display by wavelength filter.
6. 3D映画における字幕の問題について説明せよ
Explain problem related to caption in 3D theatre.
7. レンチキュラーにより視差を生成する方法について図を用いて説明せよ
Explain by figure how to achieve parallax by lenticular lens
8. パララクスバリアにより視差を生成する方法について図を用いて説明せよ
Explain by figure how to achieve parallax by barrier.
9. プルフリッヒ効果について説明せよ
Explain Pulfrich effect