

Interactive System  
インタラクティブシス  
テム特論(8)

Hiroyuki Kajimoto  
kajimoto@hc.uec.ac.jp

Twitter ID kajimoto

Hash tag #itsys

# Schedule

- 4/10 講義(lecture)1
- 4/17講義(lecture)2
- 4/24出張のため休講
- 5/1講義(lecture)3
- 5/8講義(lecture)4
- 5/15講義(lecture)5
- 5/22出張のため休講
- 5/29講義(lecture)6: **東3-306 (301は学会で使用)**
- 6/5講義(lecture)7
- 6/12講義(lecture)8
- 6/19講義(lecture)9: **論文候補提示**
- 6/26 出張のため休講
- 7/3 出張のため休講
- 7/10プレゼンテーション(presentation)1
- 7/17プレゼンテーション(presentation)2
- 7/24出張のため休講
- 7/31プレゼンテーション(presentation)3

# Outline of the lecture

1. 人間計測手法／Measuring Human
2. 視覚／Human Vision System
3. 視覚センシング／Visual Sensing
4. 視覚ディスプレイ／Visual Display
5. 聴覚、聴覚インタフェース／Auditory Interface
6. 触覚、触覚インタフェース／Tactile Interface
7. 触覚、触覚インタフェース2／Tactile Interface
8. **力覚、力覚インタフェース／Haptic Interface**
9. 移動感覚インタフェース／Locomotion Interface



# TODAY'S TOPIC

## 1. Haptic Perception Mechanism (other than skin sensation)

### a. Haptic Illusions

- I. Vision + Haptics
- II. Cutaneous+Haptics

## 2. Classifying Haptic Interface

### a. Grounded type

- I. Encounter type
- II. Wearing type
- III. Holding type (pen & tools)

### b. Ungrounded type

## 3. Application of Haptic Interface

### a. VR

### b. Telexistence & Communication

### c. AR

# Antagonistic Muscles

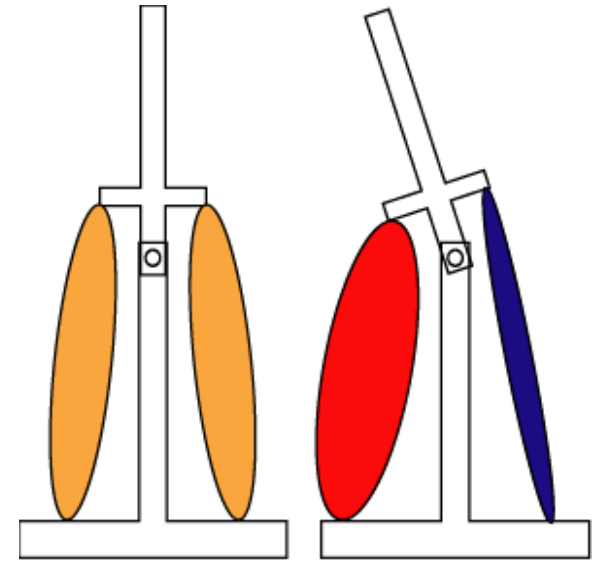
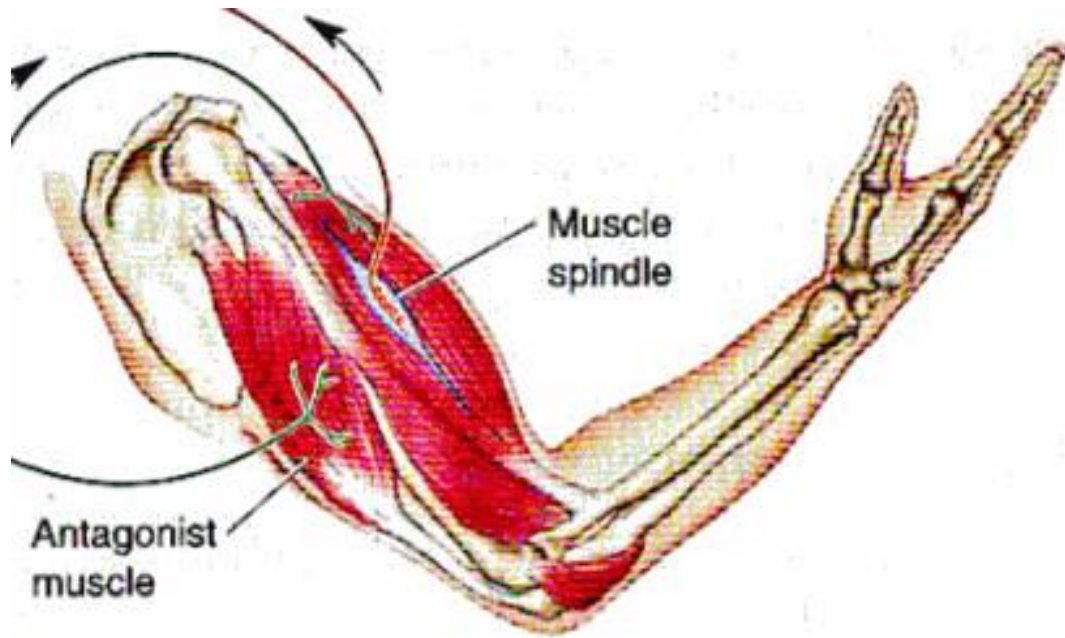

- **Two** muscles are responsible for one joint. Isn't it **redundant**?
  - Answer1: Muscle can only exert force when it shrinks.
  - Answer2: By Two muscles, “Force” and “Impedance(softness)” is independently presented.
- Muscle A – Muscle B = Exerted Force
- Muscle A + Muscle B = Joint Softness



# Receptors around Muscle and Joint

- Muscle Spindle
  - Inside Muscle
  - React to Muscle Length and Change  
=Position and Velocity
- Golgi Tendon Organ
  - At the Tendon (Muscle-Bone Connection)
  - React to Muscle Force  
=Force
- Joint Mechanoreceptor
  - Inside Joint
  - React to Joint Angle=Position
  - Limited contribution

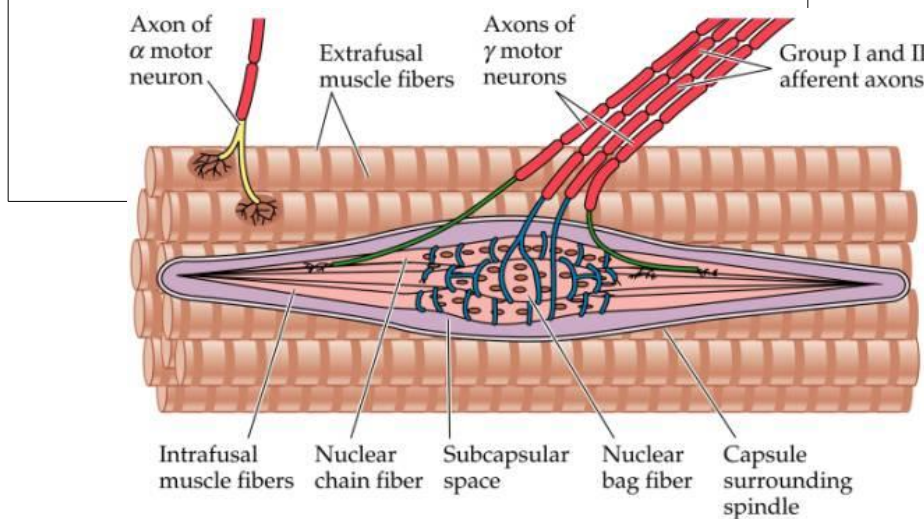
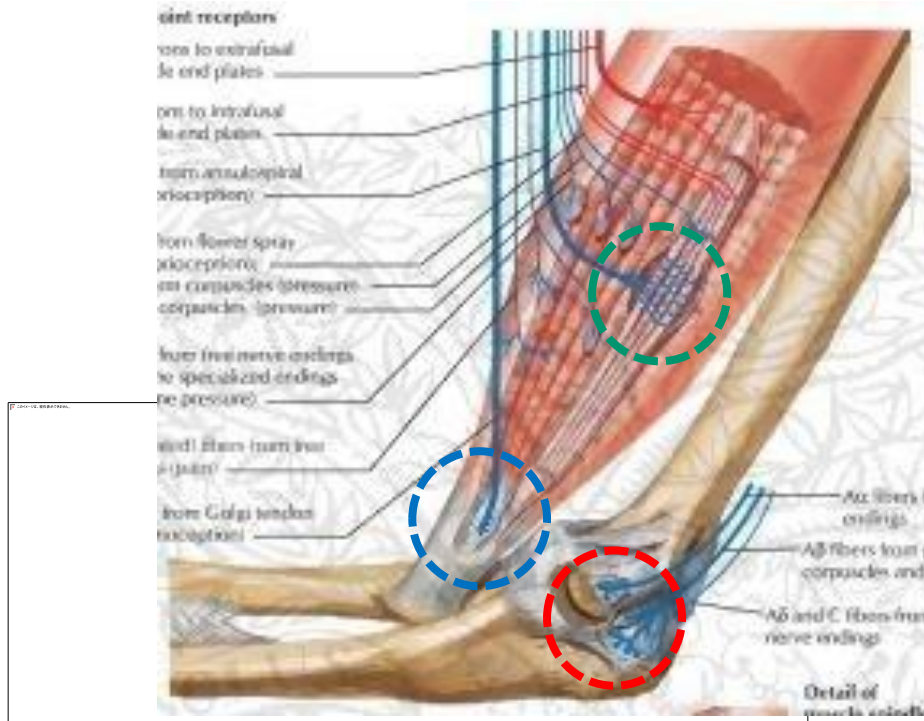

# 錯触(皮膚感覚による錯触のぞく)の一部

Haptic Illusions (part of. other than purely cutaneous illusion)

1. Vision + Haptics
2. Cutaneous(皮膚感覚) + Haptics

# 視覚によるハプティック錯覚 (1): サイズ-重さ錯覚

## Vision Induced Haptics(1): Size-Weight Illusion



同じ重量であれば、小さいものをより重く感じる。

If two objects are the same weight, smaller one felt heavier.

iPadやMacBookAirを「意外に重く」感じる理由？



# 明度⇒重さ知覚

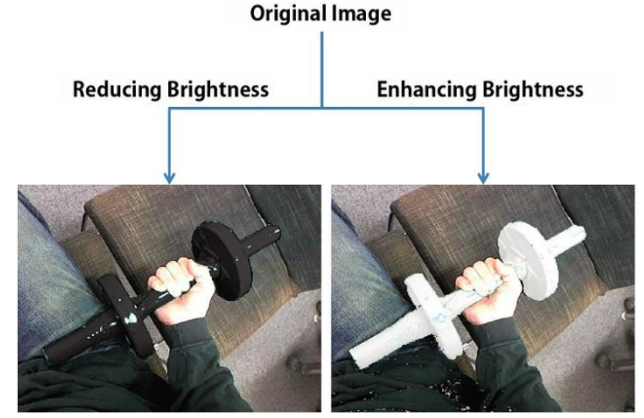
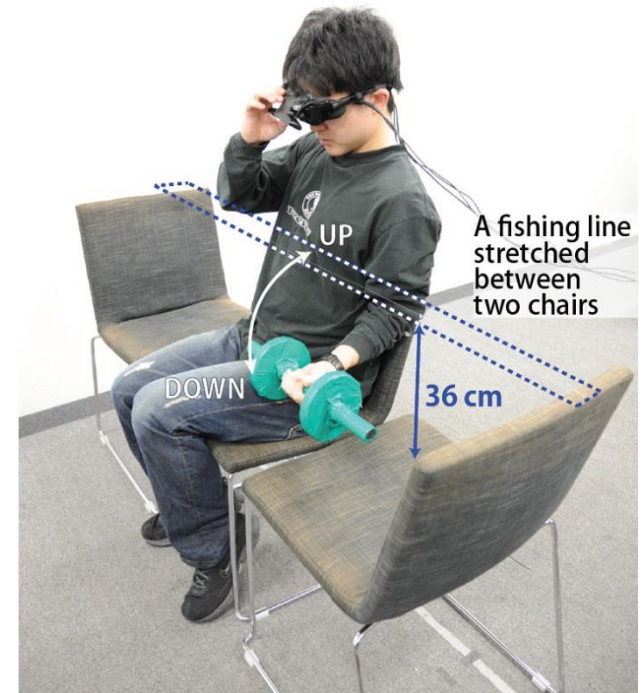
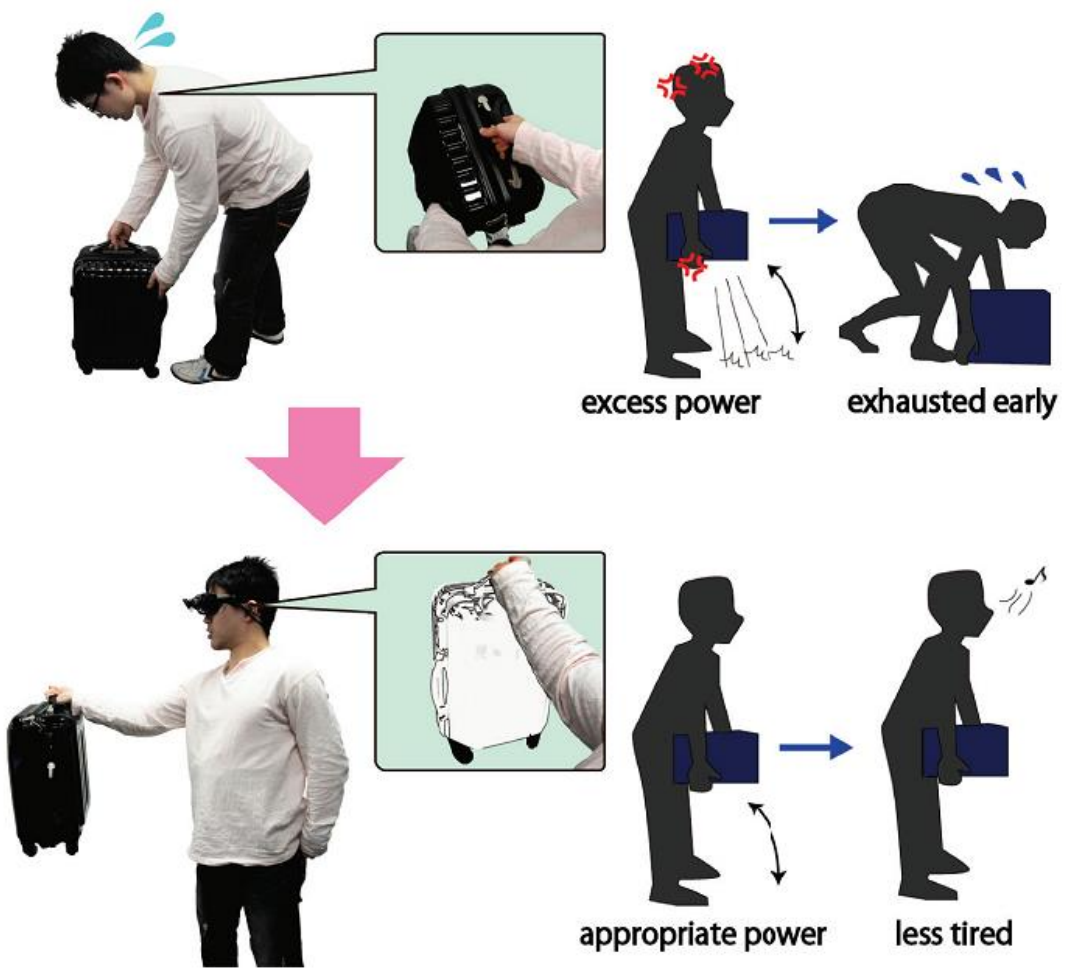

Ban et al.: Augmented Endurance: Controlling Fatigue while Handling Objects by Affecting Weight Perception using Augmented Reality, CHI2013.

# 視覚によるハプティック錯覚 (2): シュードハプティクス Vision Induced Haptics(2): Pseudo-Haptics

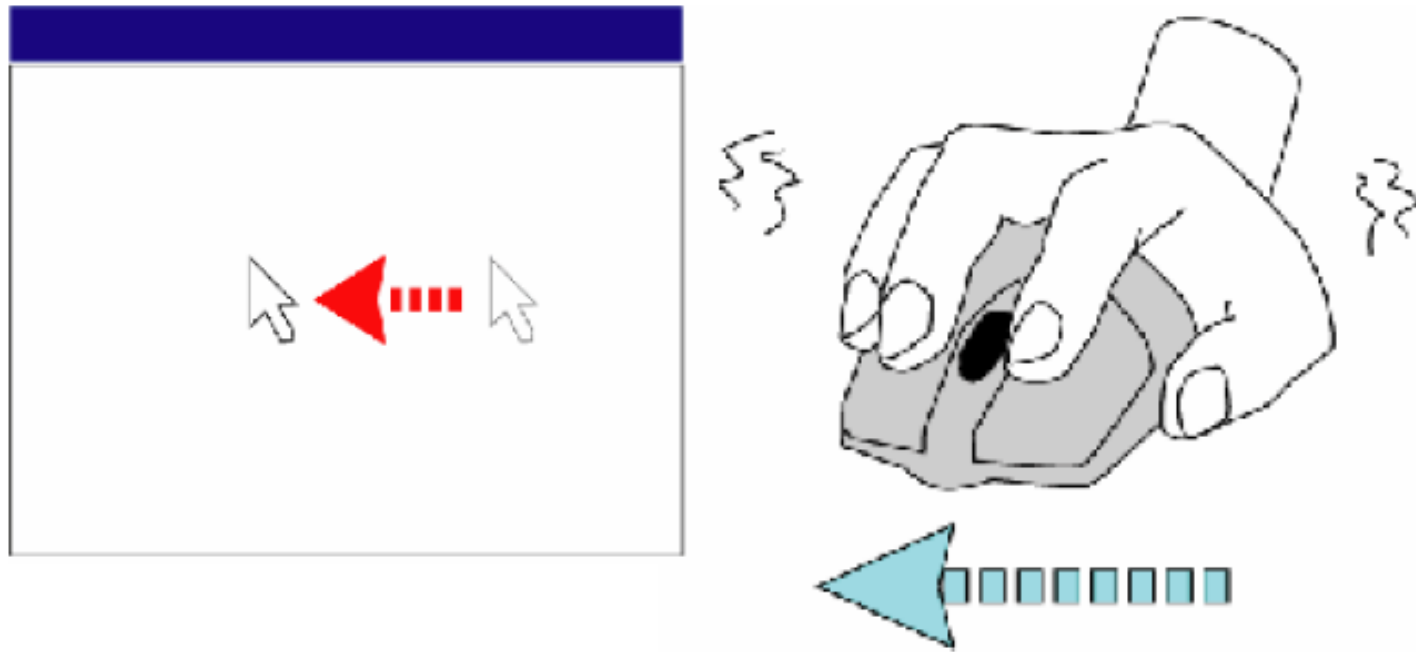

視覚的な動きによって、触覚的な抵抗感を感じる。マウスカーソルの動きを遅くしたときのブレーキ感。

Visual motion induces haptic resistance. (ex) Braking feeling when mouse cursor is suddenly slowed down.

[http://www.irisa.fr/bunraku/GENS/alecuyer/projets\\_textures.html](http://www.irisa.fr/bunraku/GENS/alecuyer/projets_textures.html)

# PseudoHaptics

## Tactile Images

[http://www.youtube.com/watch?v=F6h\\_19PxKO8](http://www.youtube.com/watch?v=F6h_19PxKO8)

# 視覚によるハプティック錯覚 (3): Rubber Hand Illusion

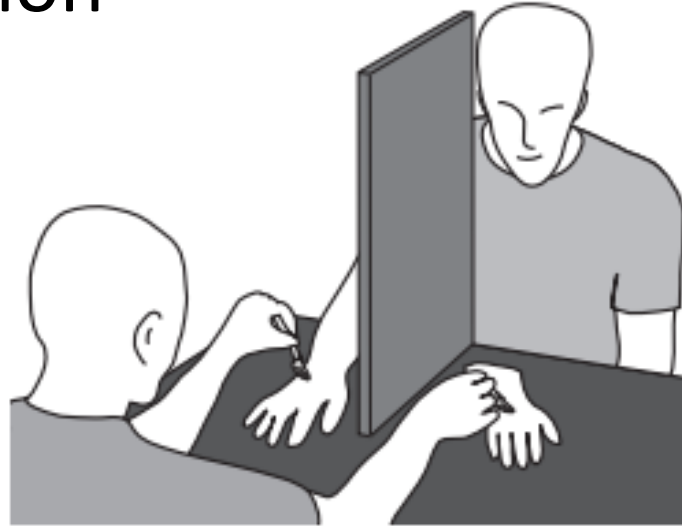

見えていない実際の手に触覚的な刺激を与え、同時にゴムの手に視覚的な刺激を与える。しばらくするとゴムの手が自分の手であるように感じる

Watching a rubber hand being stroked synchronously with one's own unseen hand causes the rubber hand to be attributed to one's own body, to "feel like it's my hand."

Botvinick, M., & Cohen, J.: Rubber hands "feel" touch that eyes see, *Nature*, 391, 756 (1998)

Armel, K. C., & Ramachandran, V. S.: Projecting sensations to external objects: evidence from skin conductance response, *Proc R Soc Lond B Biol Sci*, 270, 1499-1506 (2003)

# Rubber Hand Illusion



[http://www.youtube.com/watch?v=nzF\\_DfOafKw&feature=related](http://www.youtube.com/watch?v=nzF_DfOafKw&feature=related)



# Rubber Hand Illusionの拡張



早稲田大学 河合隆史研究室  
「触運動錯覚呈示システム」  
@DCExpo2010

[http://www.youtube.com/watch?v=aixTxO5gCpE&feature=player\\_embedded](http://www.youtube.com/watch?v=aixTxO5gCpE&feature=player_embedded)

イリュージョンが生じている状態で視覚的な刺激だけを動かすと、触覚を与えられていないにもかかわらず「モワッ」とした感覚を生じる。

While Rubber Hand Illusion is induced, Only visual stimulus is moved.  
Then we feel vague tactile sensation.

# 視覚によるハプティック錯覚 (4): ミラーボックスによる幻肢痛の緩和 Reduction of phantom pain by mirror box

幻肢痛: 手足を失った後に、切断部位は問題ないのに激しい痛みを感じる現象。

ひとつの仮説: 失った手足の脳内座標(ボディマップ)が狂い、体内に「食い込む」ことで脳内で痛みシグナルが発生。姿勢をもとに戻せないために痛みを生じ続ける。

Phantom pain: After one's hand/arm/leg was removed, pain seems to occur from the removed site.

One hypo.: Removed limb's body map in the brain comes wrong, and the brain generates pain signal.

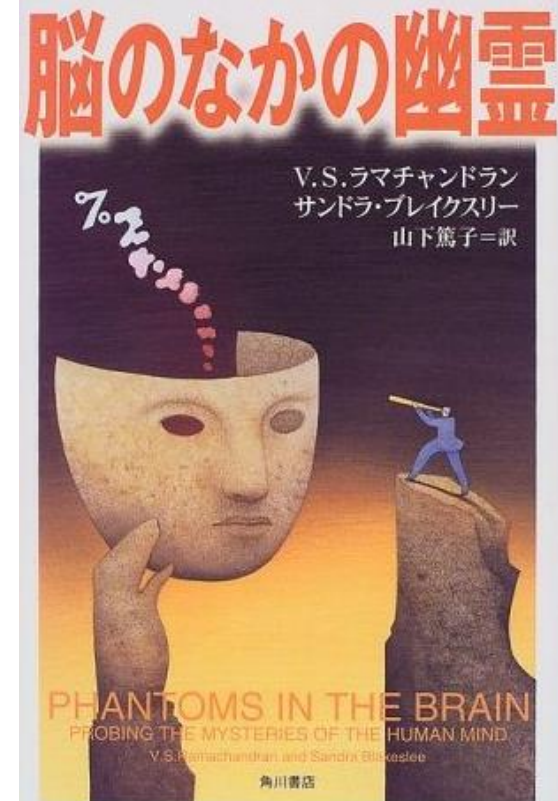
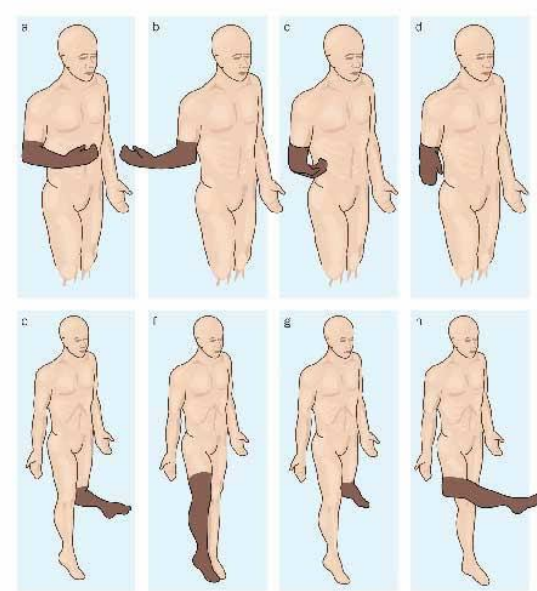

# ミラーボックスセラピー

## Mirror box therapy

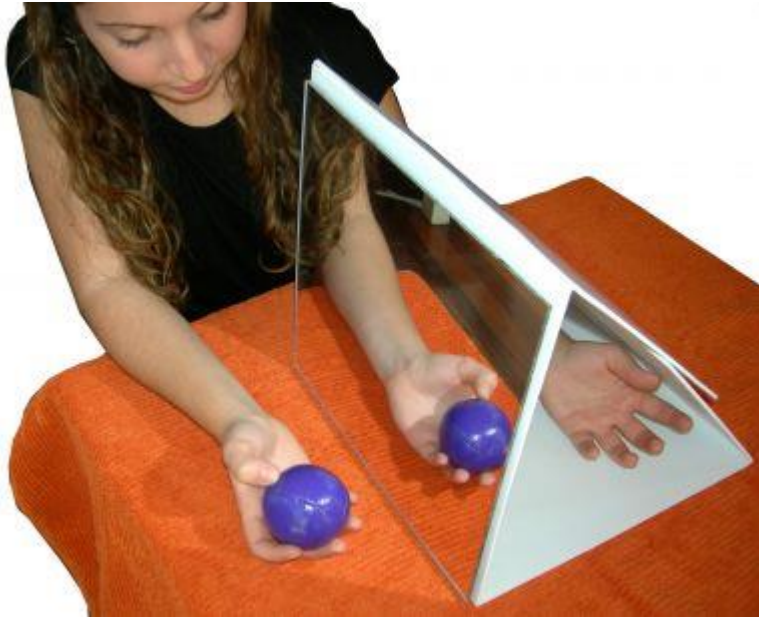

ミラーボックスを使い、両手を使っていることをイメージさせることで、脳内で無いはずの手を動かすことができる。これにより幻肢痛を劇的に低減できる。

Using mirror box, patients can “move” their lost limb in their brain, so that the phantom pain is dramatically reduced.





# (参考)視覚による痛みの低減

## Visually small reduces pain

### INCREDIBLE SHRINKING PAIN

Last month, researchers at Oxford University announced the discovery of a powerful new painkiller: inverted binoculars. The scientists found that subjects who looked at a wounded hand through the wrong end of binoculars, making the hand appear smaller, felt significantly less pain and even experienced decreased swelling. According to the researchers, this demonstrates that even basic bodily sensations such as pain are modulated by what we see. So next time you stub your toe or cut a finger, do yourself a favor: look away.



反転させた双眼鏡を使って痛みの患部を観察すると痛みが減る。  
Observing the pain region with reverted binocular, the pain is reduced.

G. Lorimer Moseley, Timothy J. Parsons<sup>1</sup> and Charles Spence “Visual distortion of a limb modulates the pain and swelling evoked by movement,” 2008

# 皮膚感覚によるハプティック錯覚 Cutaneous Induced Haptics : ピノキオ錯覚-1 / Pinocchio Illusion-1



## THE PINOCCHIO ILLUSION

This requires two chairs and a blindfold. The person wearing the blindfold should sit in the rear chair, staring at the back of the person sitting in front. The blindfolded person should then reach around and place one hand on the other person's nose. At the same time, he should put his other hand on his own nose, and begin gently stroking both noses. After about a minute, more than

50 percent of subjects report that their nose feels incredibly long.



自分の前の人の鼻を撫でつつ、自分の鼻も撫でると、1分程度で半分程度の人が自分の鼻が伸びたように感じる。Rubber Hand Illusionの視覚無し版として理解可能



# 皮膚感覚によるハプティック錯覚 Cutaneous Induced Haptics: 伸展錯覚とピノキオ錯覚-2 / Extention Illusion & Pinocchio Illusion-2

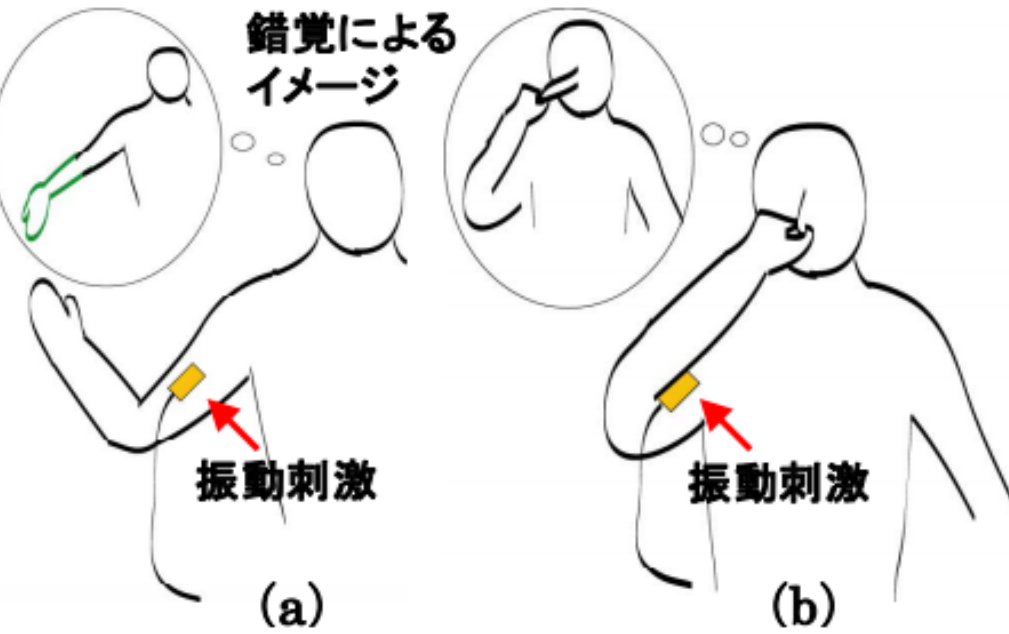

伸展錯覚: 筋肉に強い振動刺激を与えると、反射によって収縮する。  
⇒ 収縮を妨害すると、筋肉が伸びたような錯覚

Extention Illusion: Strong vibration to muscle induces shrink reflex. If this shrink is blocked, illusion of muscle extention occurs.

鼻を摘んだ状態でやると鼻が伸びる。  
Doing while pinching nose, the nose grows like Pinocchio.

図2 腱振動刺激による運動錯覚  
(a) 伸展錯覚, (b) ピノキオ錯覚

Fig.2 Illusory kinesthesia by tendon vibration  
(a) An extension illusion, (b) Pinocchio illusion

# 皮膚感覚によるハプティック錯覚 Cutaneous Induced Haptics: ハンガー反射／Hanger Reflex

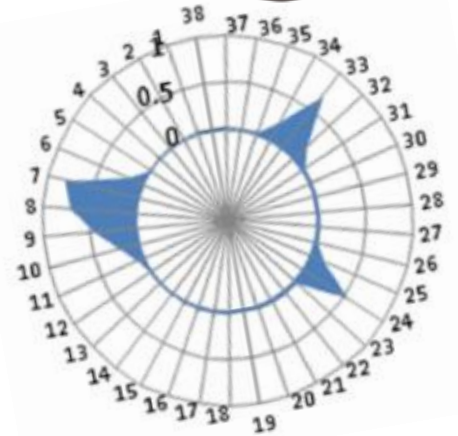
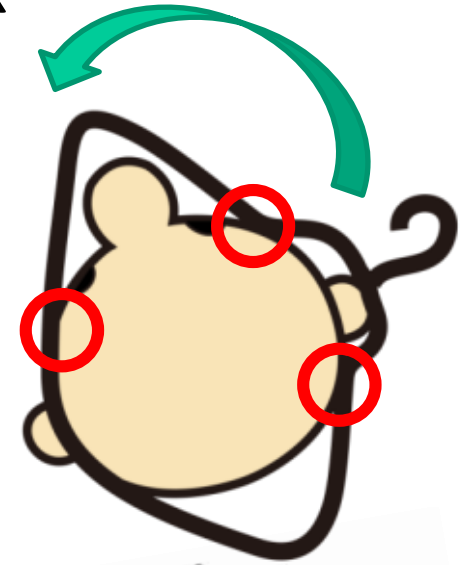

- 側頭部圧迫によって外力を知覚
- 頭部の回旋をも誘発
- Front temporal pressure induces “rotational” force perception.
- Rotation itself is induced.

# ハンガー反射



To clarify the details of the HR,  
we measured pressure distribution  
on the head when the reflex took place,

# ハンガーマシン Hanger Machine





# (参考)ハンガー反射現象の解明と痙性斜頸への応用



- ✓ 痙性斜頸: 全国に**推定1万人**程度
- ✓ 富山大医学部で**ハンガー反射**が有効
- ✓ 今後40人程度の患者による治験必要



# (参考) 痙性斜頸への応用

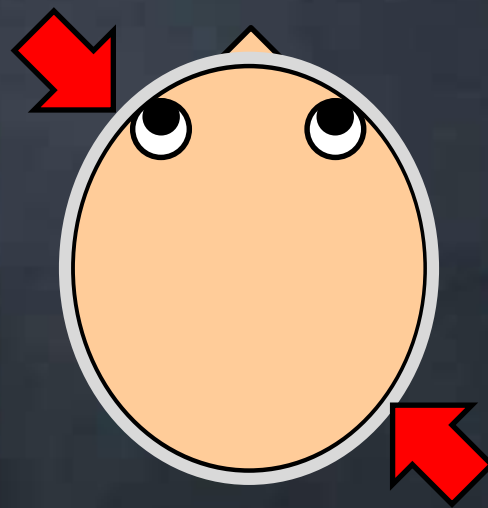
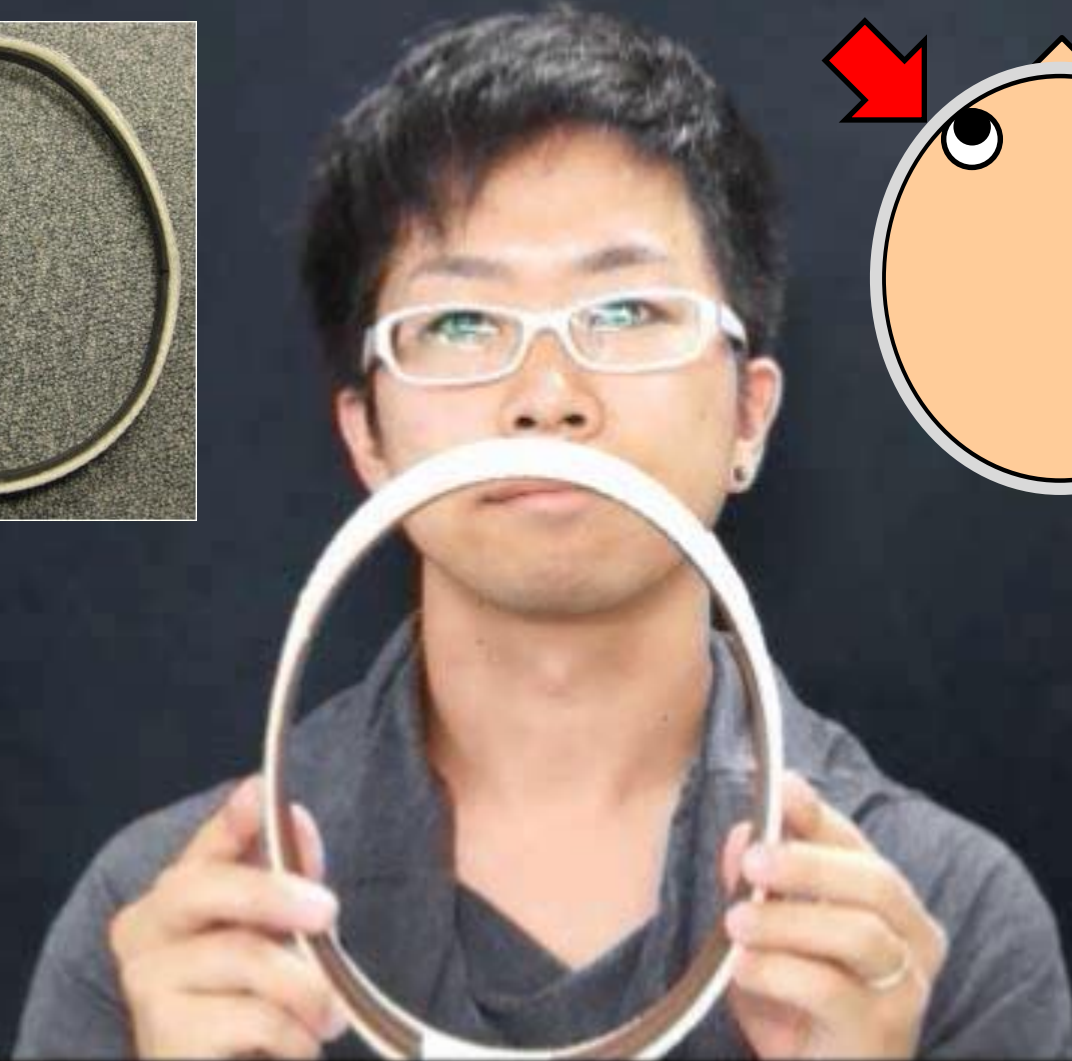

富山大、順天堂大等と共同研究中

# 皮膚圧迫による外力錯覚

## Illusory external force by pressure



稲葉、藤田：指先圧迫による擬似反力提示装置の提案と試作,日本バーチャルリアリティ学会論文誌,2007.  
Minamizawa, Haptic Interface for Middle Phalanx Using Dual Motors, EuroHaptics, 2006.

- 皮膚の圧迫により、本来は外力がない状況で外力を感じる
- Simple pressure sensation is perceived as external force.

# TODAY'S TOPIC

## 1. Haptic Perception Mechanism (other than skin sensation)

### a. Haptic Illusions

- I. Vision + Haptics
- II. Cutaneous+Haptics

## 2. Classifying Haptic Interface

### a. Grounded type

- I. Encounter type
- II. Wearing type
- III. Holding type (pen & tools)

### b. Ungrounded type

## 3. Application of Haptic Interface

### a. VR

### b. Telexistence & Communication

### c. AR

# How to reconstruct the world?

- Reconstruct Shape

- 遭遇型 / Encounter Type

- High Cost, but free hand

- True “Contact” = Natural Tactile Sensation

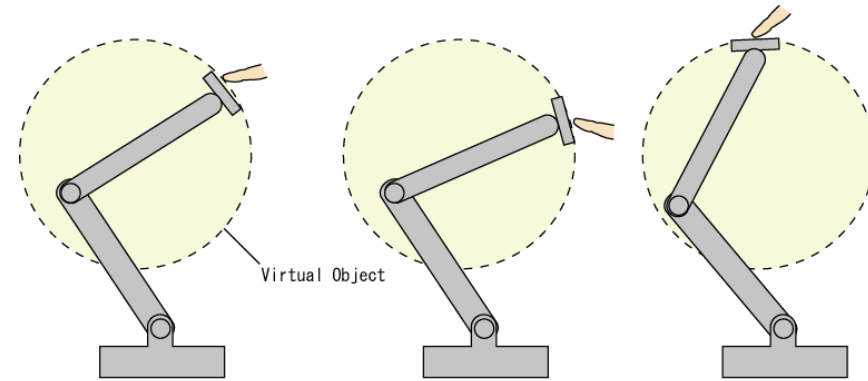

- Reconstruct Hand Shape

- 装着型・把持型 /

- Wear Type, or Grip Type

- Low Cost but must equip

- Most Commercial Haptic Interface

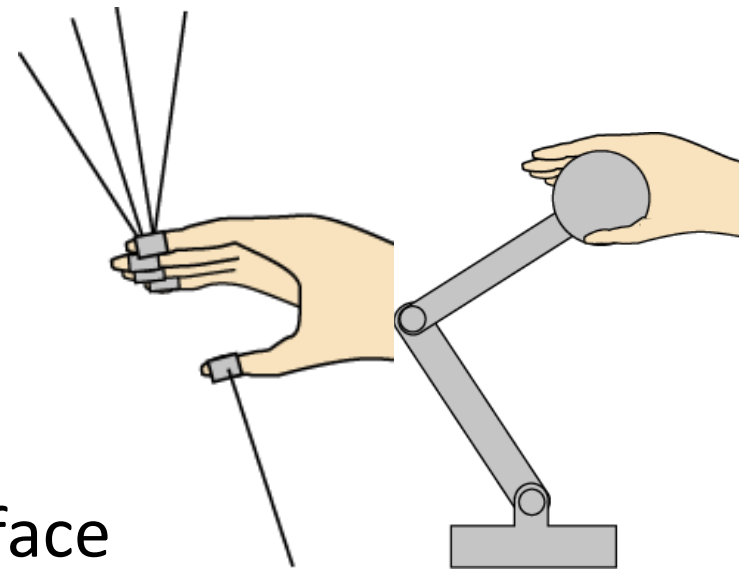

# 遭遇型 / Encounter Type(1)

## Active Environment Display (Tachi et al., 1994)

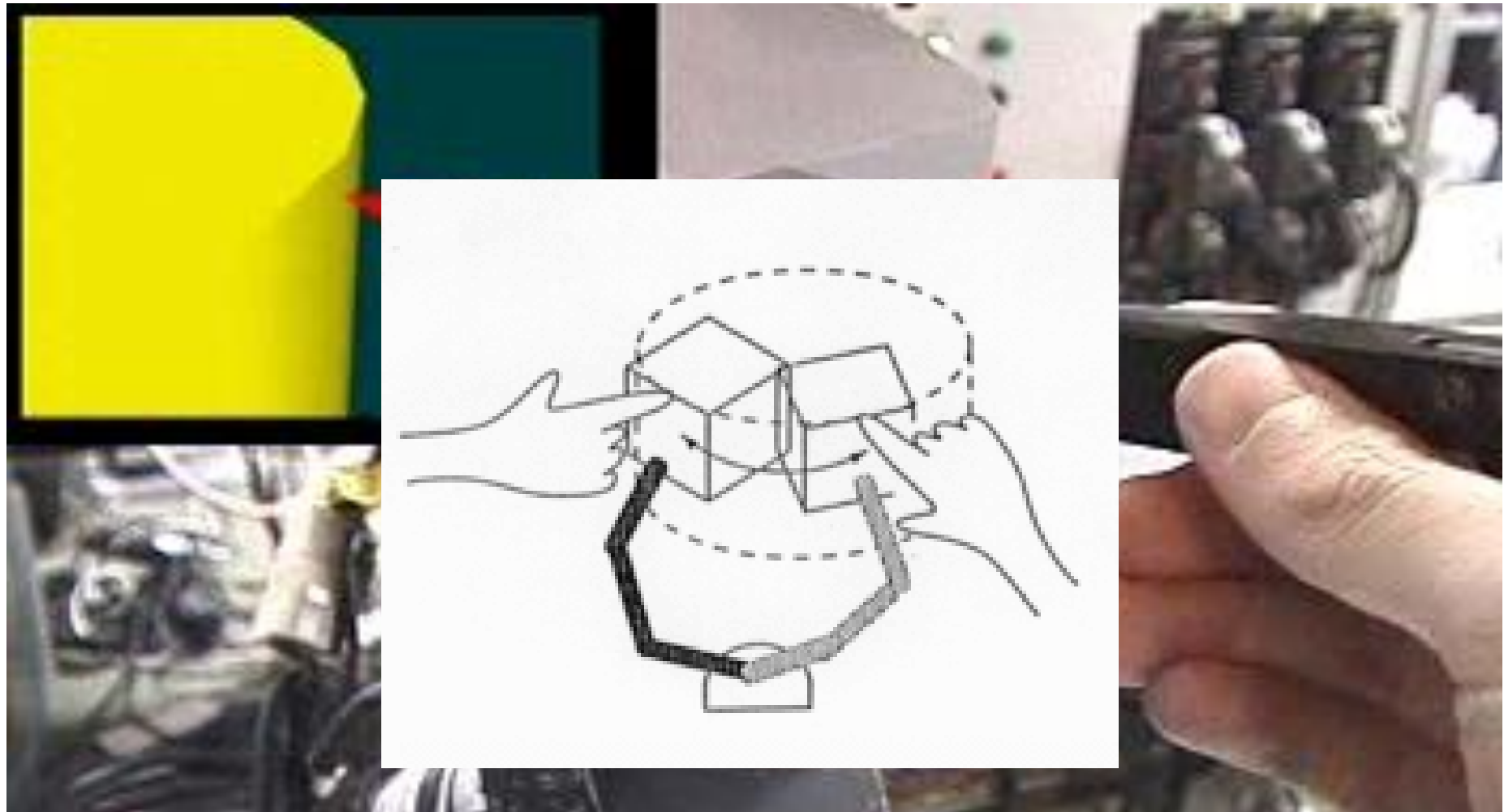

S. Tachi, T. Maeda, R. Hirata and H. Hoshino: A Construction Method of Virtual Haptic Space, Proceedings of the 4th International Conference on Artificial Reality and Tele-Existence (ICAT '94), pp.131-138, Tokyo, Japan (1994.7)

<http://tachilab.org/modules/projects/aed.html>



# Encounter Type II TELESAR II master hand (2005)

- Space between finger and display is kept constant.
- When Virtual Object contacts, it is displayed.

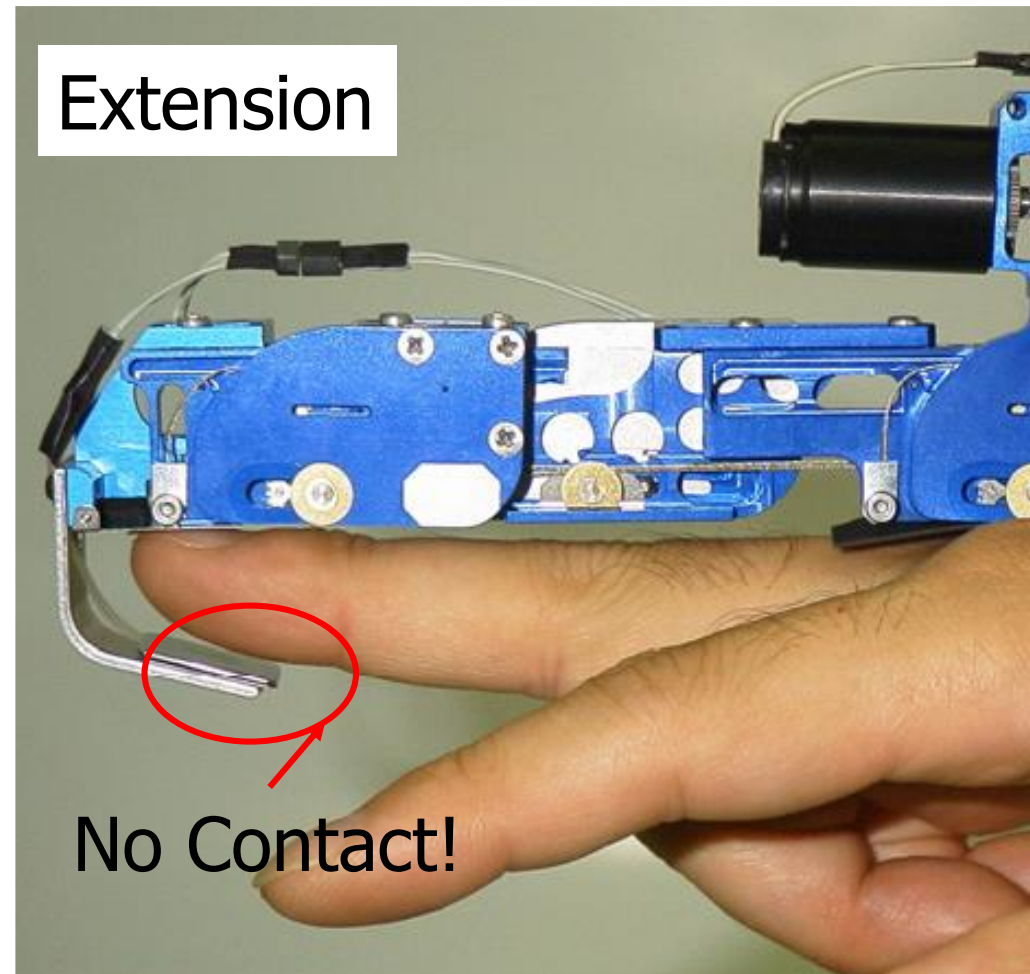
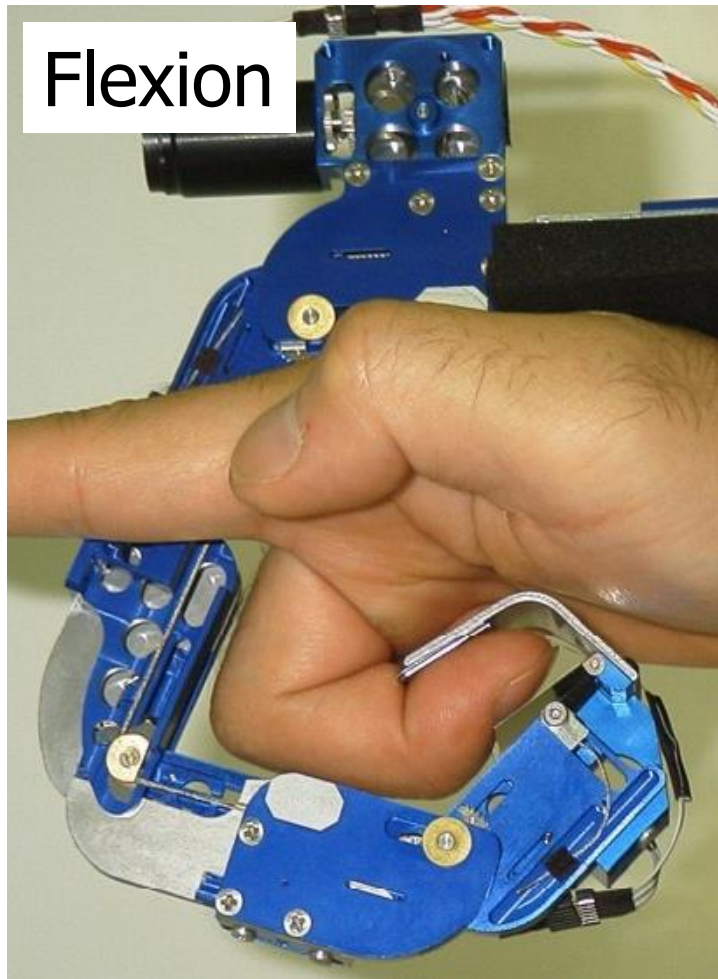

# TELESAR II master hand

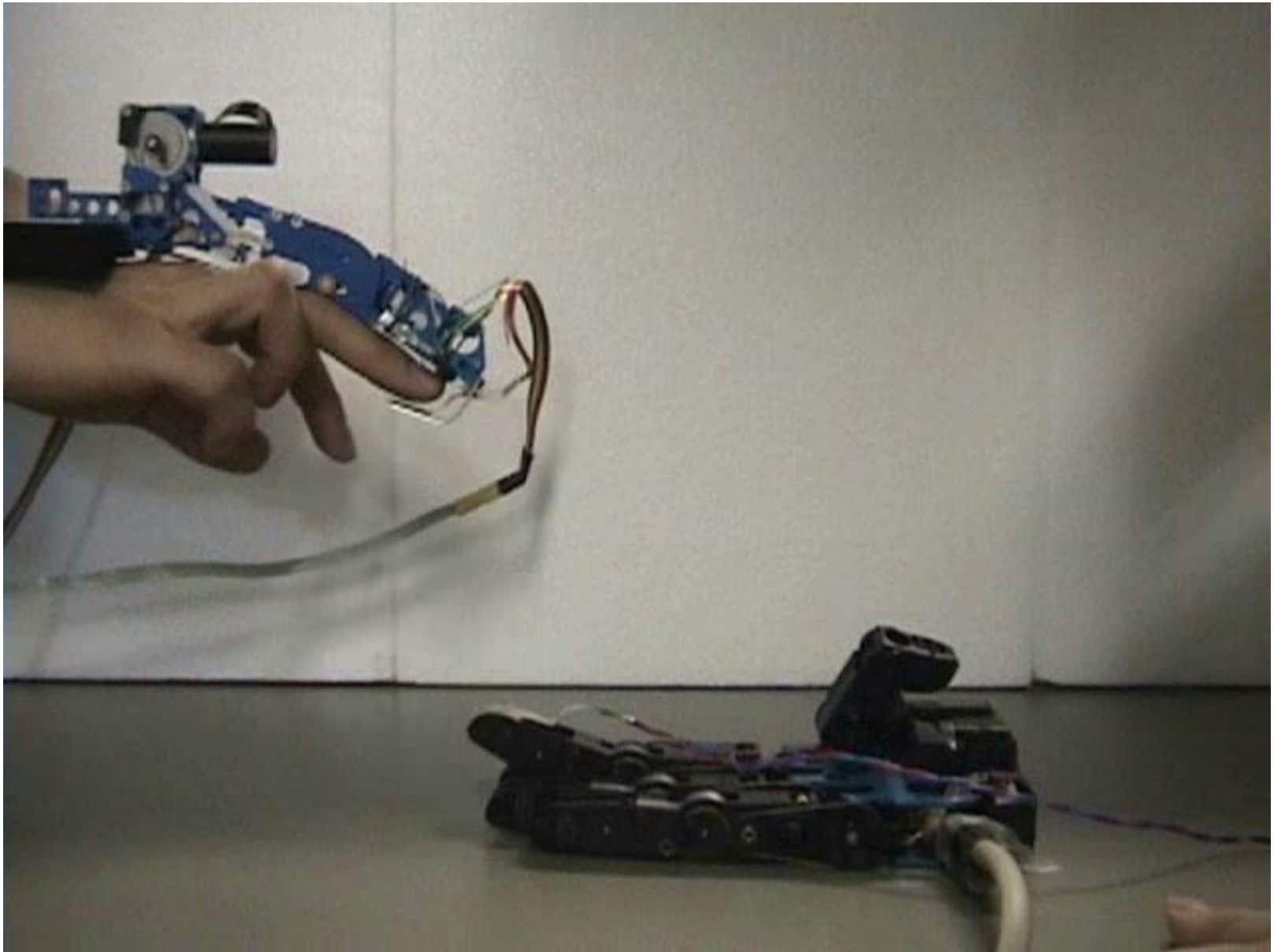

# TELESAR II master hand (thumb)

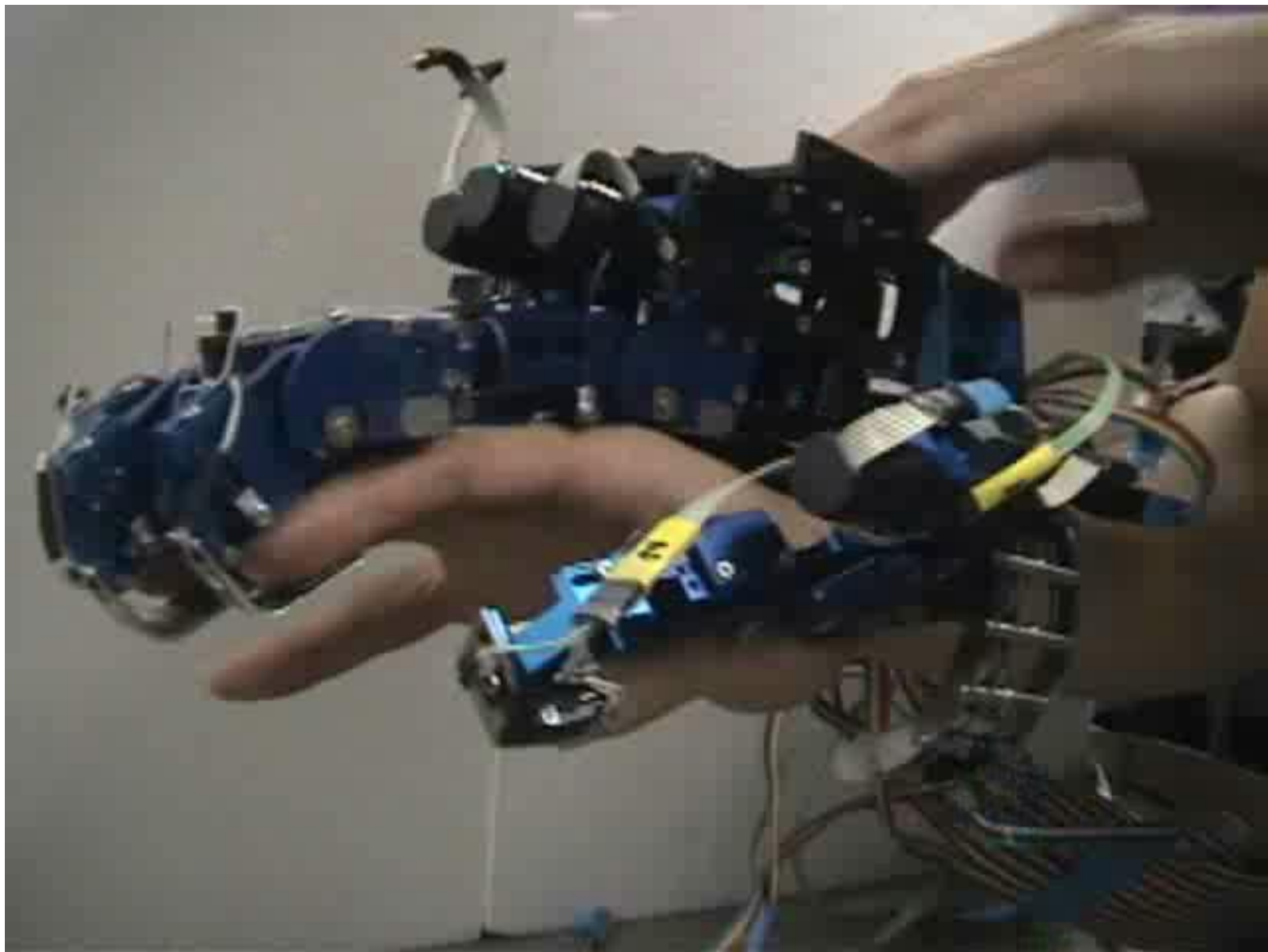

# How to reconstruct the world?

- Reconstruct Shape

- 遭遇型 / Encounter Type
- High Cost, but free hand
- True “Contact” = Natural Tactile Sensation

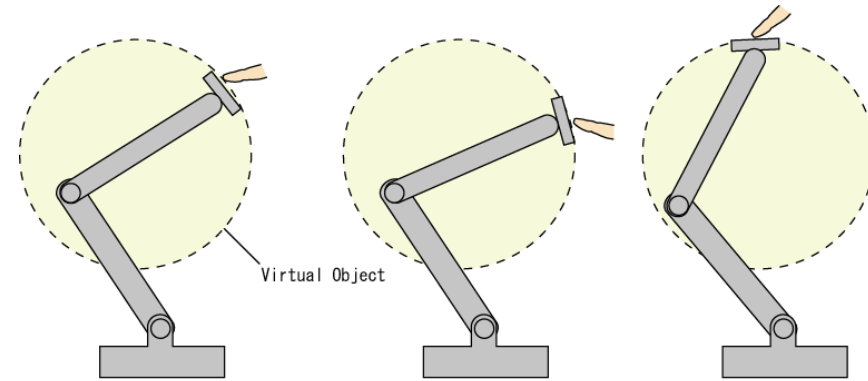

- Reconstruct Hand Shape

- 装着型・把持型 /  
Wear Type, or Grip Type
- Low Cost but must equip
- Most Commercial Haptic Interface

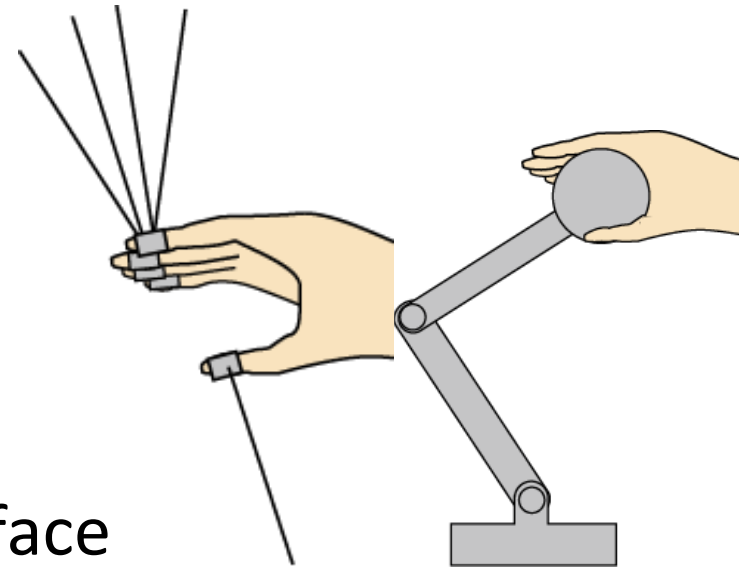



# Wear Type: CyberGrasp/CyberForce

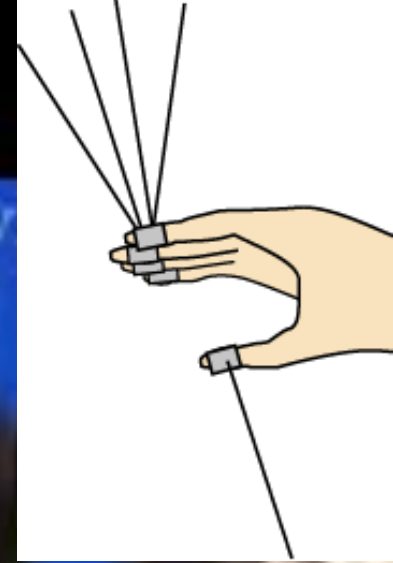

<http://www.youtube.com/watch?v=Td7QcAgCtWE&feature=fvw>



# Wear Type(2)SPIDAR-8(WALAIRACHT et al., 1999)

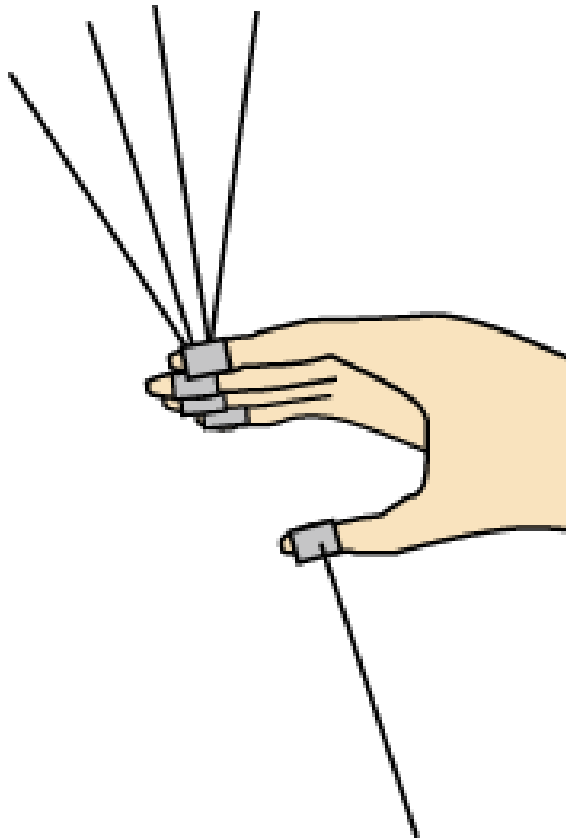

- (left) 4 finger, (right) 4 finger
- One finger is pulled by 3 wires

# 対向型多指触覚インターフェイス(Kawasaki et al.)

## Five-Fingered Haptic Interface



<http://www.youtube.com/watch?v=Xx1YY0xo4gk&feature=related>

# Wear Type(3) Electrical Stimulation

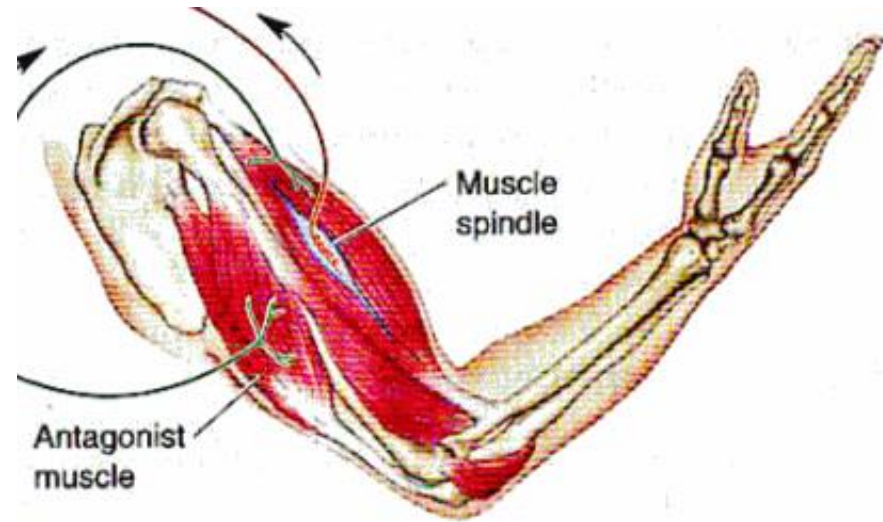
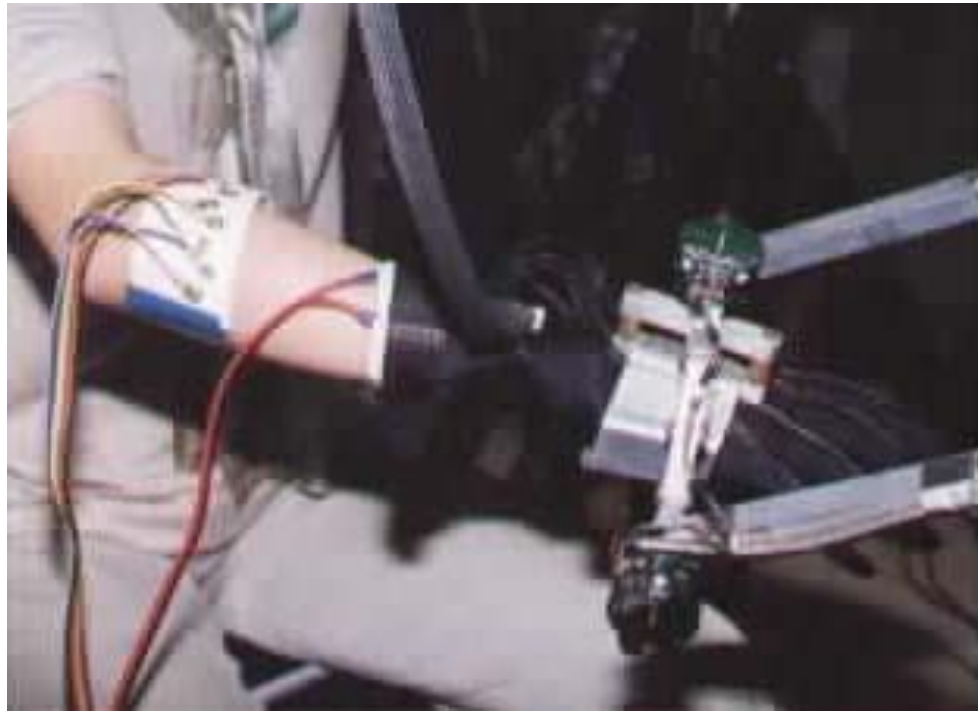

稲見, 川上: 仮想体感装置, 特開平7-20978

- 拮抗筋の電気刺激で抵抗力を提示
- 軽量。ただし刺激場所での触覚も生じる
- Antagonist Muscle is electricall stimulated.
- Light weight, but strong tactile sensation also.

IVRC1993

ARMSII  
ARMS  
東京工業大学

(OIVRC/IVTV)



# (参考) 指を動かす筋肉 / Muscles for fingers

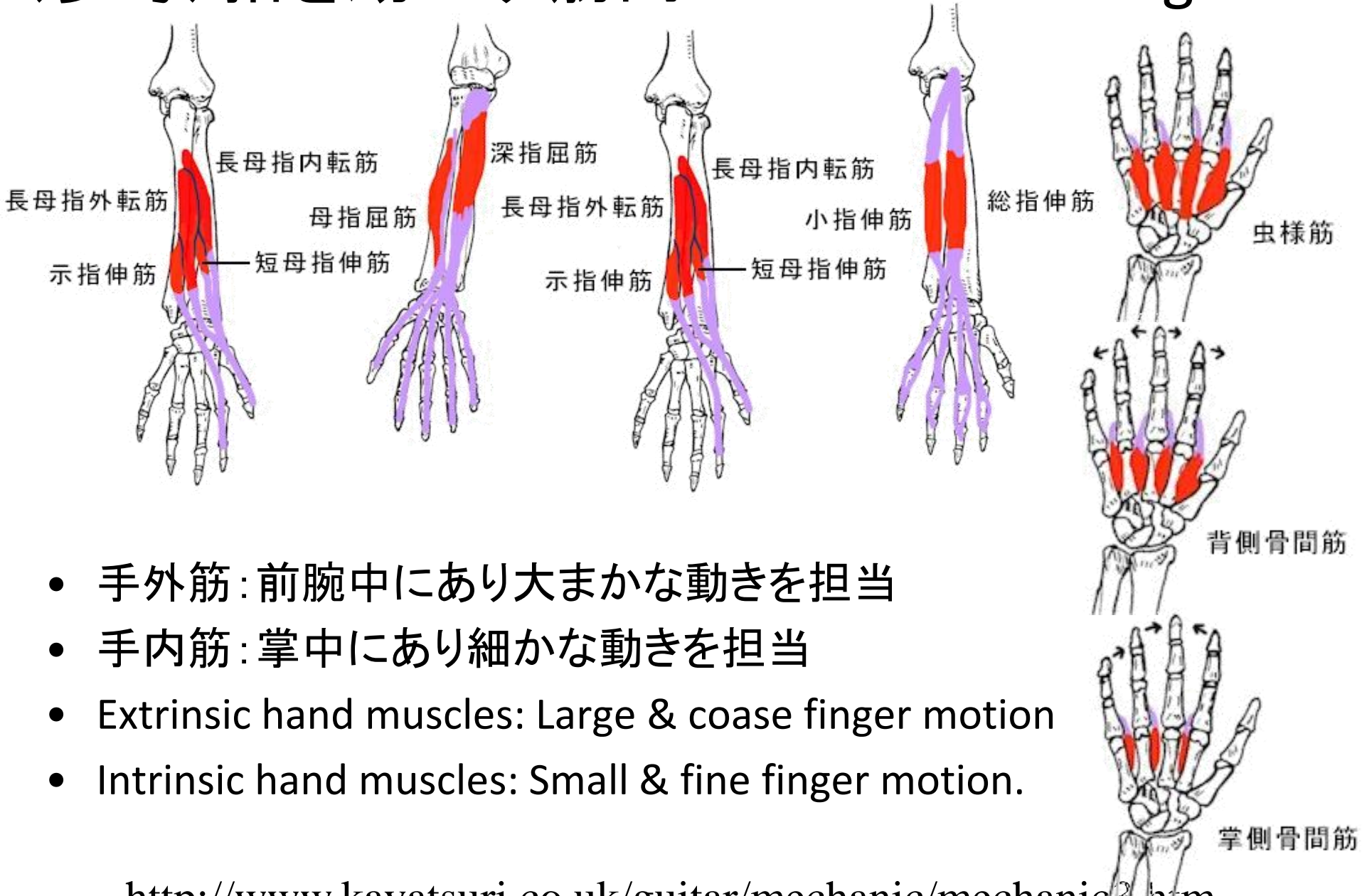

- 手外筋: 前腕中にあり大まかな動きを担当
- 手内筋: 掌中にあり細かな動きを担当
- Extrinsic hand muscles: Large & coarse finger motion
- Intrinsic hand muscles: Small & fine finger motion.



# Posessed Hand



<https://www.youtube.com/watch?v=9XBoZyfB8hY>

# 機能的電気刺激

## Functional Electrical Stimulation

video

- 主にリハビリテーションで用いられる。
- 日常生活の補助(=長期的な刺激)にはなお課題。
- Mainly used in rehabilitation.
- Several problems remains for long-term stimulation.

# (参考) 外骨格型パワーアシスト Power support by exoskeleton

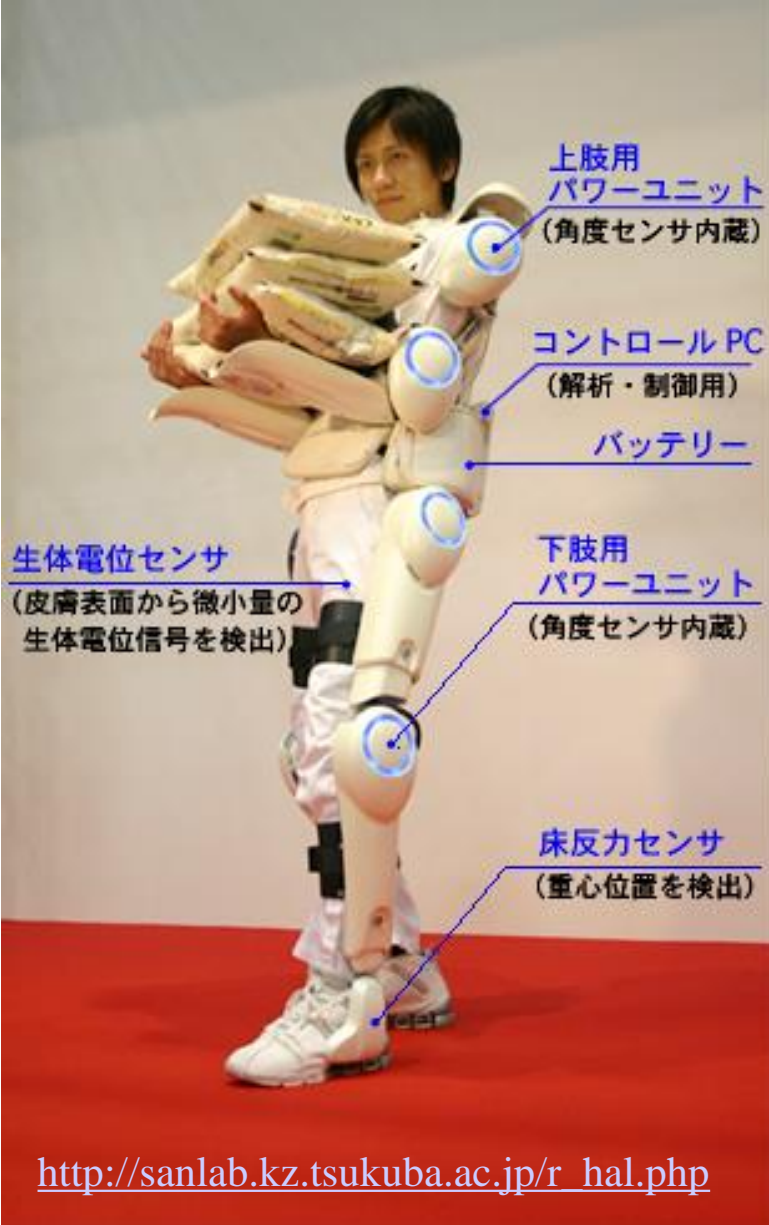

筑波大学山海研究室 HAL



General Electric "Hardiman" (1965)

# How to reconstruct the world?

- Reconstruct Shape

- 遭遇型 / Encounter Type
- High Cost, but free hand
- True “Contact” = Natural Tactile Sensation

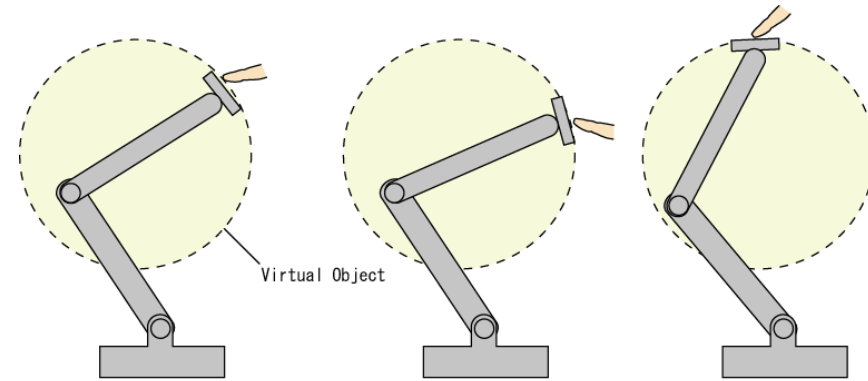

- Reconstruct Hand Shape

- 装着型・把持型 /  
Wear Type, or Grip Type
- Low Cost but must equip
- Most Commercial Haptic Interface

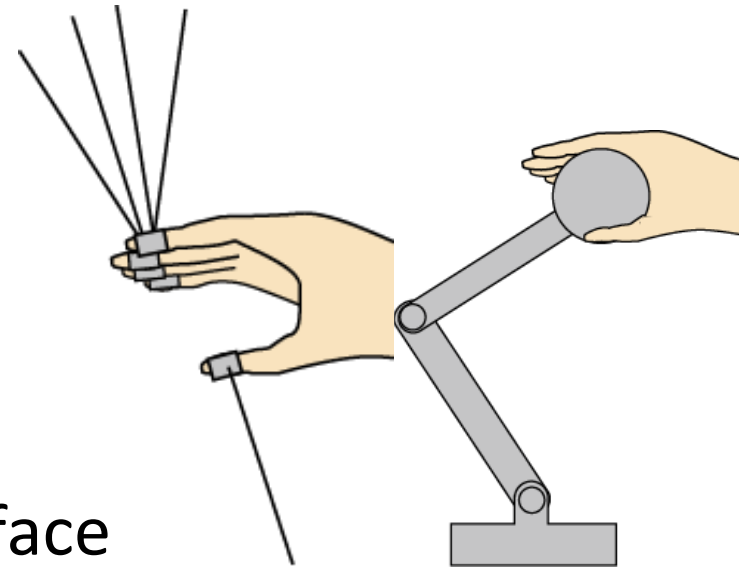

# Grip type(1)

## PHANTOM (SensAble)

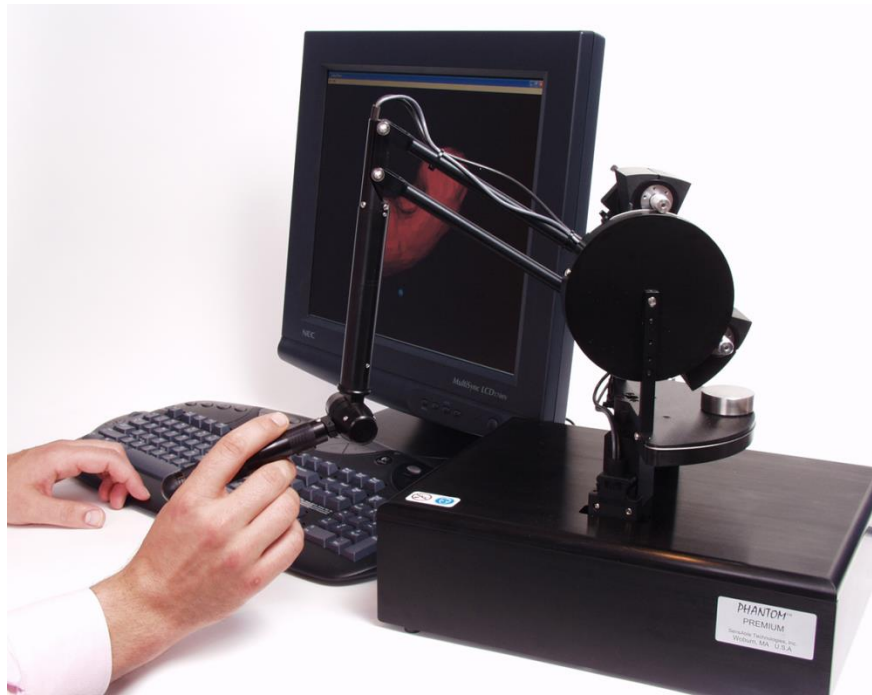

- 最も有名なハプティックデバイス。6自由度をサポート
- 指サックタイプも開発されたが多くはペングリップタイプ
- Most Famous Haptic Interface with 6DOF
- Fingerstall type was developed, but most are pen-grip type

Massie T. H., Salisbury J. K., "The PHANTOM Haptic Interface: A Device for Probing Virtual Objects," Symposium on Haptic Interfaces for Virtual Environment and Teleoperator Systems, 1994.



# 装着型と把持型の小さくて大きな違い

Small but significant difference between wear type and grip type



- 装着型／Wear type:

- 指ごとにサポートする必要  
Each finger must be supported
- 古典的VR/ Classical VR

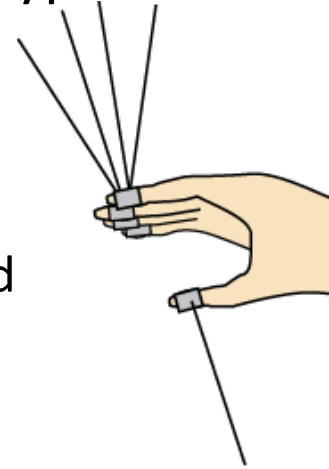

- 把持型／Grip type:

- 「ペン」等の類推の利く**道具**に対して力提示(道具再現型). 指への力提示は間接的  
Force is presented to “Tool”, and presentation to hand is indirect.
- 現実的解/  
Practical solution for many applications

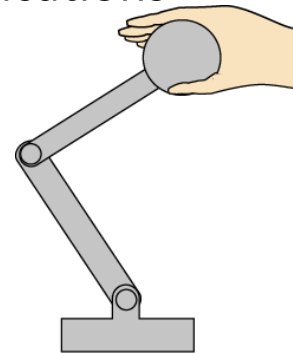

# Grip type(1)PHANToM (SensAble)



<http://www.youtube.com/watch?v=u9jdhUvOmMw&feature=related>

# Grip type(1)PHANToM Omni

Cheaper version with 3DOF

<http://www.youtube.com/watch?v=REA97hRX0WQ>

# Omega (force dimension)

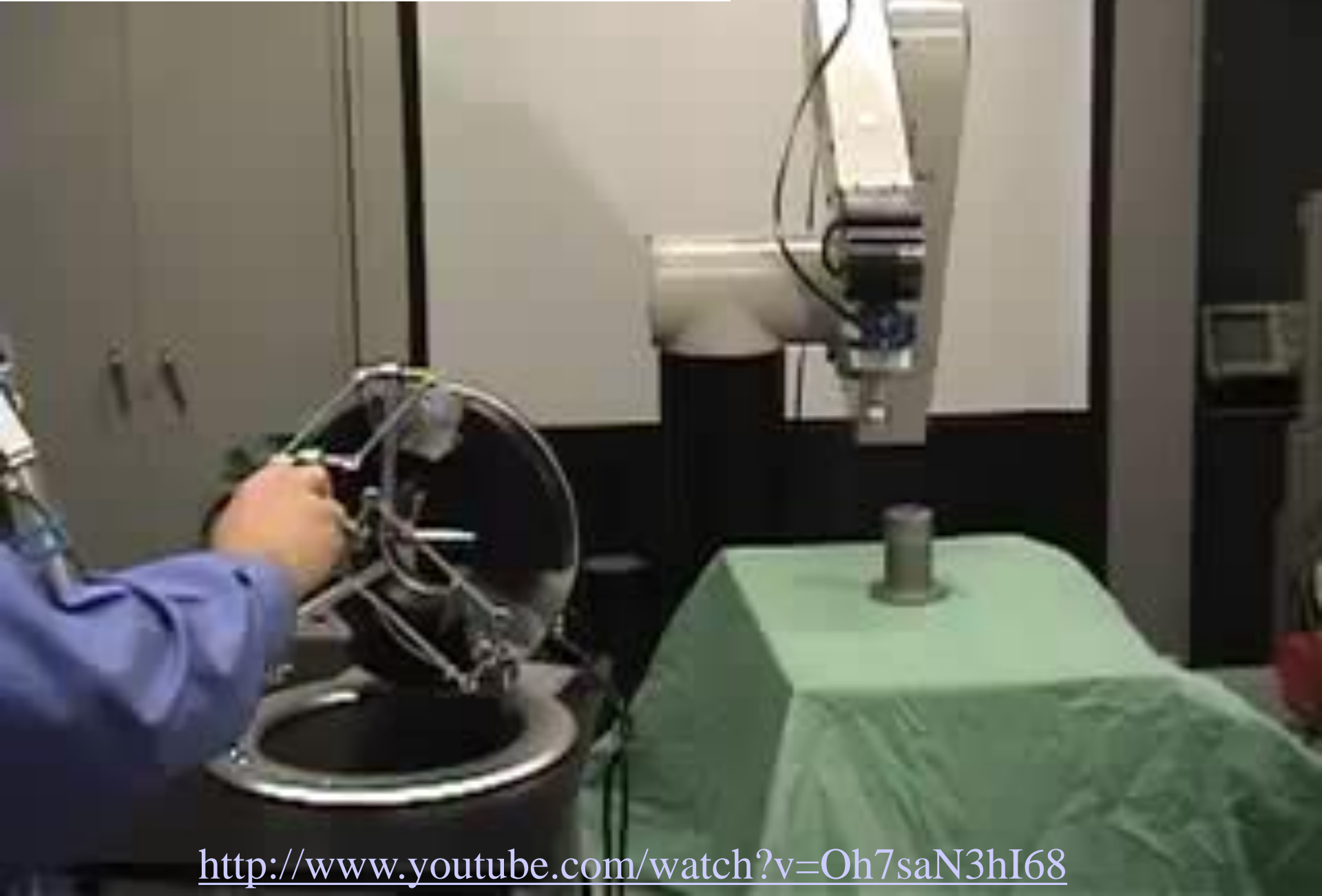

<http://www.youtube.com/watch?v=Oh7saN3hI68>



# Falcon (Novint)



<http://www.youtube.com/watch?v=mW70eIK9Yrs&feature=related>

- 格安ハプティックデバイス。ゲーム用途で販売
- Very cheap haptic device is sold for gaming use



# SPIDAR-G

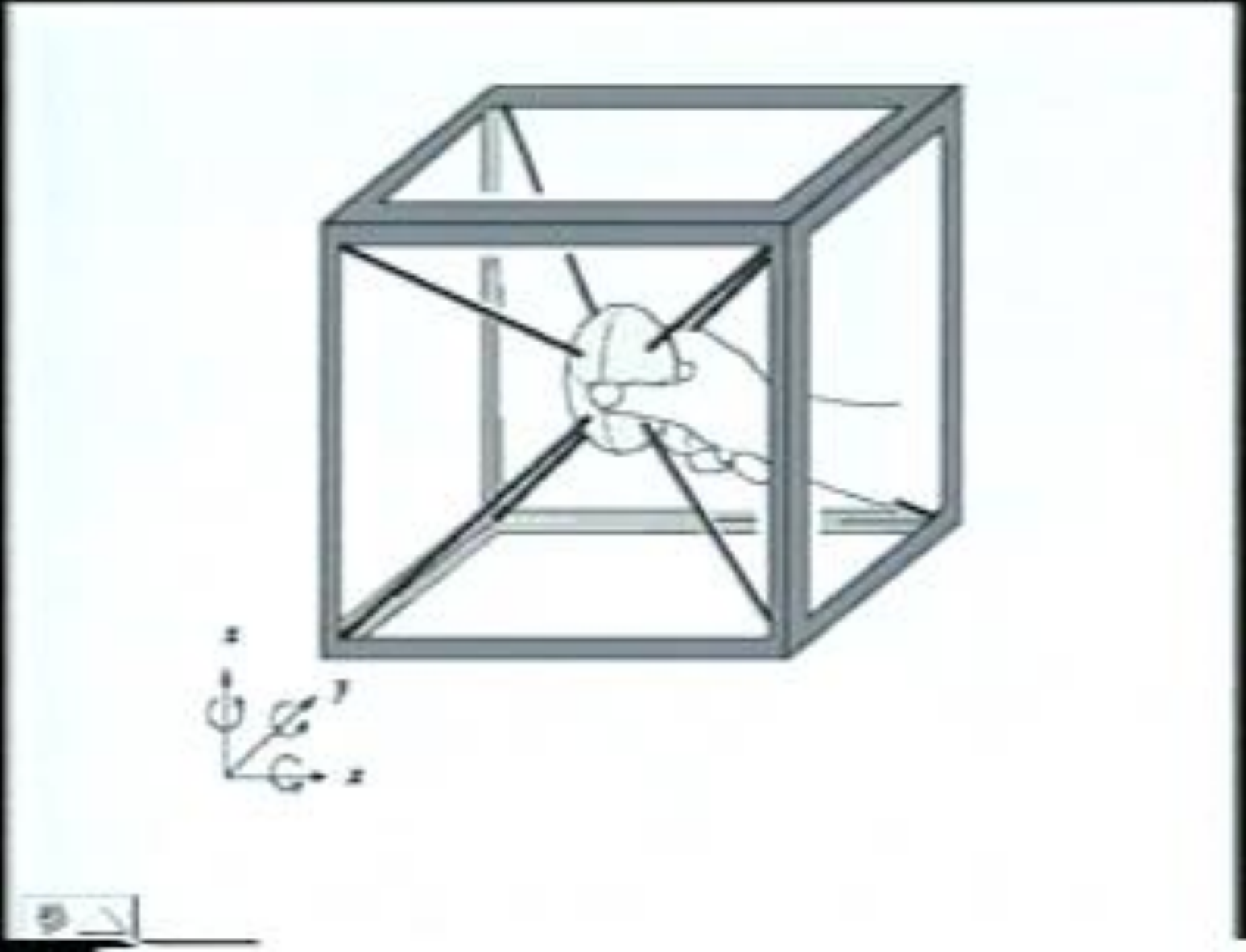

# Magrev

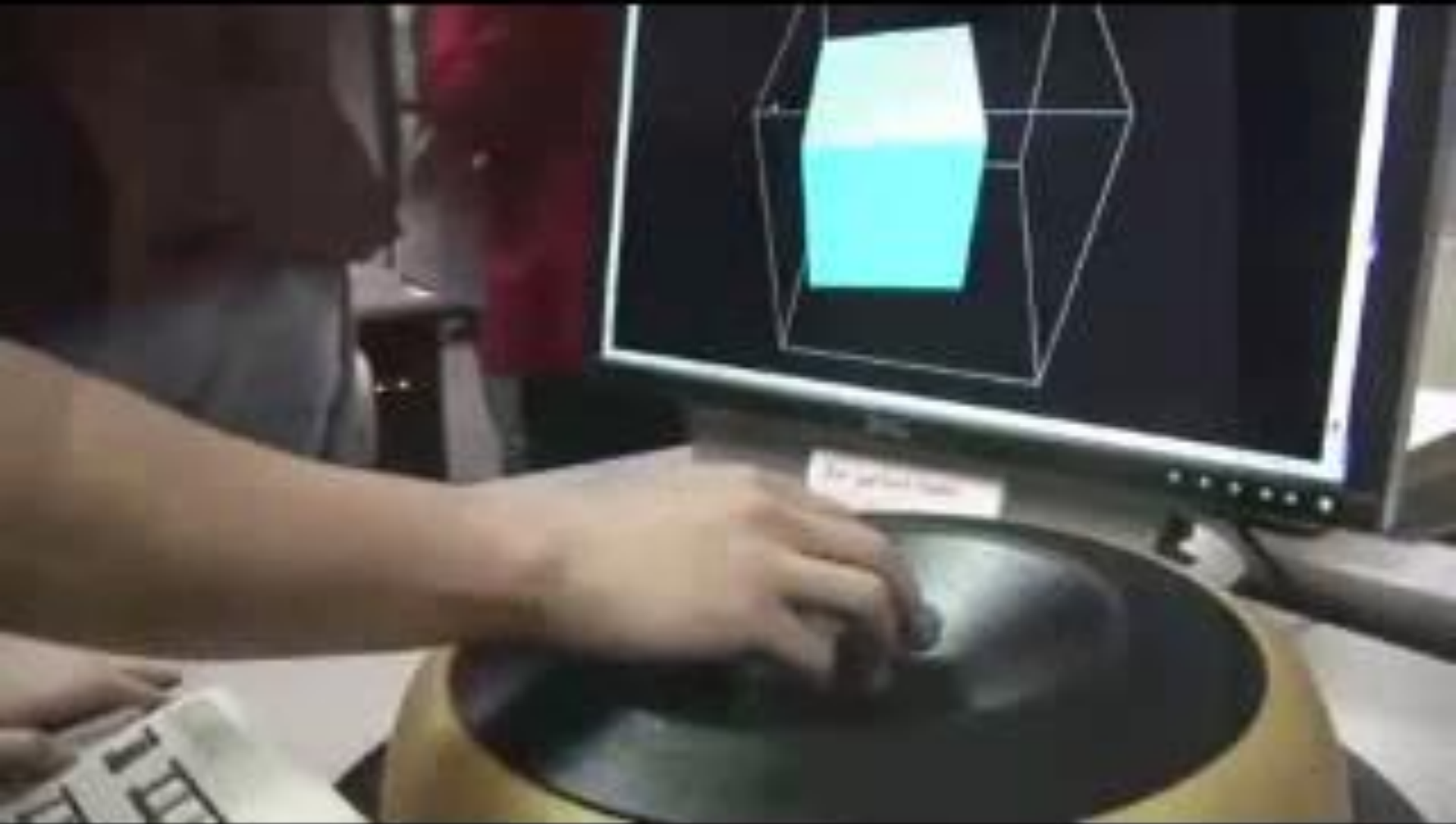

<http://www.youtube.com/watch?v=cMi75SrDbSk&feature=related>

# Large Field Haptic Display



**Antonia Perez (2009) A NOVEL HAPTIC INTERFACE FOR EXTENDED RANGE TELEPRESENCE: CONTROL AND EVALUATION**

[http://www.youtube.com/watch?v=J3KVekC9\\_Mg&feature=related](http://www.youtube.com/watch?v=J3KVekC9_Mg&feature=related)

# HapticMaster (MOOG FCS)



Van der Linde R.Q., Lammertse P., Frederiksen E., Ruitter B(2002) **The HapticMaster, a new high-performance haptic interface**

- 産業用ロボット的なバックドライバビリティのない剛構造＋力センサ
- Rigid structure without back-drivability, like industrial robot. With force sensor



# 軽く作るかしっかりつくるか? Make it **light**, or make it **rigid**?

- バックドライバビリティ / back-drivability  
= 出力軸を直接動かせるかどうか  
Whether output shaft can be moved directly
- 通常の歯車 / Ordinary gear  
バックドライバビリティ有. ただしギア比が大きいほど減少(1:50程度)  
Back-drivable, but reduced if gear ratio is higher.
- ウォームギア / Worm gear:  
バックドライバビリティ無  
Not back-drivable.



ハプティックインタフェースは出力軸を直接触るから、バックドライバブルかどうかで制御方式が変わってくる。

As Human handles output shaft directly, control method is closely related to back-drivability



軽く作るかしっかりつくるか? Make it **light**, or make it **rigid**?



- 「軽い」装置:

- ワイヤ駆動等. 低ギア比.
- バックドライバビリティ有)



- 「固い」装置:

- 産業用ロボットなど.
- 高ギア比. ユーザは動かせない.
- ハンドル先端のカセンサに応答.

# 「軽い」装置の制御方法

How to control “light” haptic interface?

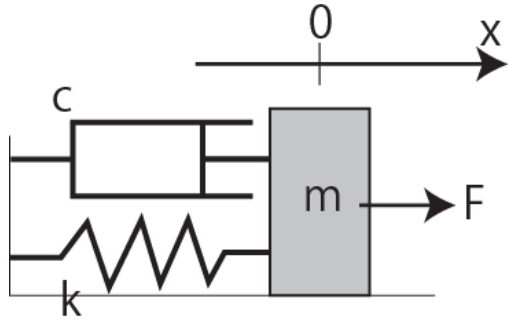

$$m\ddot{x} = f - c\dot{x} - kx$$

## インピーダンス型のシミュレート手法

- 手先の位置を計測.
- 位置や速度に応じた力を出力.
- 手先が壁にめり込むところから開始するから、力覚ディスプレイは操作者の力だけで動かせる必要＝バックドライバビリティ有

## Impedance based method

- Measure grip position.
- Output force according to the position and velocity.
- As in the first step, position must be changed by the user, the haptic interface must be back-drivable.

# 「堅い」装置の制御方法

How to control “rigid” haptic interface?

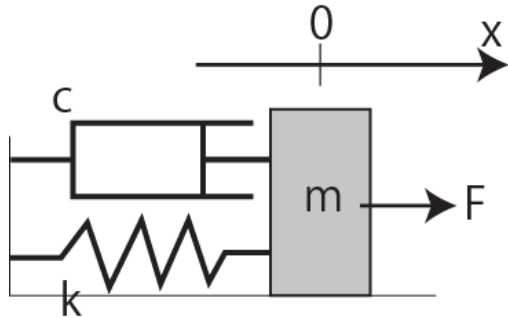

$$m\ddot{x} = f - c\dot{x} - kx$$



アドミッタンス型のシミュレート手法

- 操縦者の力を計測
- その力に基づき、手先がどう動くか計算。その軌道を出力。
- 手先に力センサ必須だが、バックドライバビリティは不要，産業用ロボット等の固い装置を利用可能

Admittance based method

- Measure operator's force
- Calculate world's behavior according to the force, and change position of the grip.
- Force sensor is necessary, but back-drivability is not. Rigid robot can be used such as industrial robot.

# TODAY'S TOPIC

## 1. Haptic Perception Mechanism (other than skin sensation)

### a. Haptic Illusions

- I. Vision + Haptics
- II. Cutaneous+Haptics

## 2. Classifying Haptic Interface

### a. Grounded type

- I. Encounter type
- II. Wearing type
- III. Holding type (pen & tools)

### b. Ungrounded type

## 3. Application of Haptic Interface

- a. VR
- b. Telexistence & Communication
- c. AR



# ジャイロ効果の利用/ Using gyro effect



ジャイロ効果の利用: 定速回転→回転軸変動

Using gyro effect: Rotation axis is turned



吉江 将之、矢野博明、岩田 洋夫 : ジャイロモーメントを用いた力覚呈示装置、日本VR学会論文誌Vol.7 No.3(2002)

[http://intron.kz.tsukuba.ac.jp/gyro/gyro\\_j.html](http://intron.kz.tsukuba.ac.jp/gyro/gyro_j.html)

GyroCube: 回転速度変化/ Rotation speed is changed

GyroCube

中村, 福井, "GyroCubeを用いたHapticCompassの提案", 感覚代行シンポジウム, 2003



1つのモータ回転

<http://staff.aist.go.jp/n-nakamura/HapticNavi/movie.html>

# Virtual Chanbara(2001) 回転速度の急な変化→衝撃

Sudden change of rotation speed induces impulse



Daijiro Koga et al., Virtual Chanbara, Siggraph2002

<http://www.siggraph.org/s2002/conference/etech/virtual.html>



# 偏加速度の利用／Using Asymmetric Acceleration

Buru-Navi (Amemiya et al.)

[http://www.youtube.com/watch?v=Yj\\_WnNWV8F4](http://www.youtube.com/watch?v=Yj_WnNWV8F4)

# Buru-Navi Application(Amemiya et al.)

<http://www.youtube.com/watch?v=xoxbADarD4k>

# GyroCube Sensuous: 偏加速度の利用

## GyroCubeSensuous

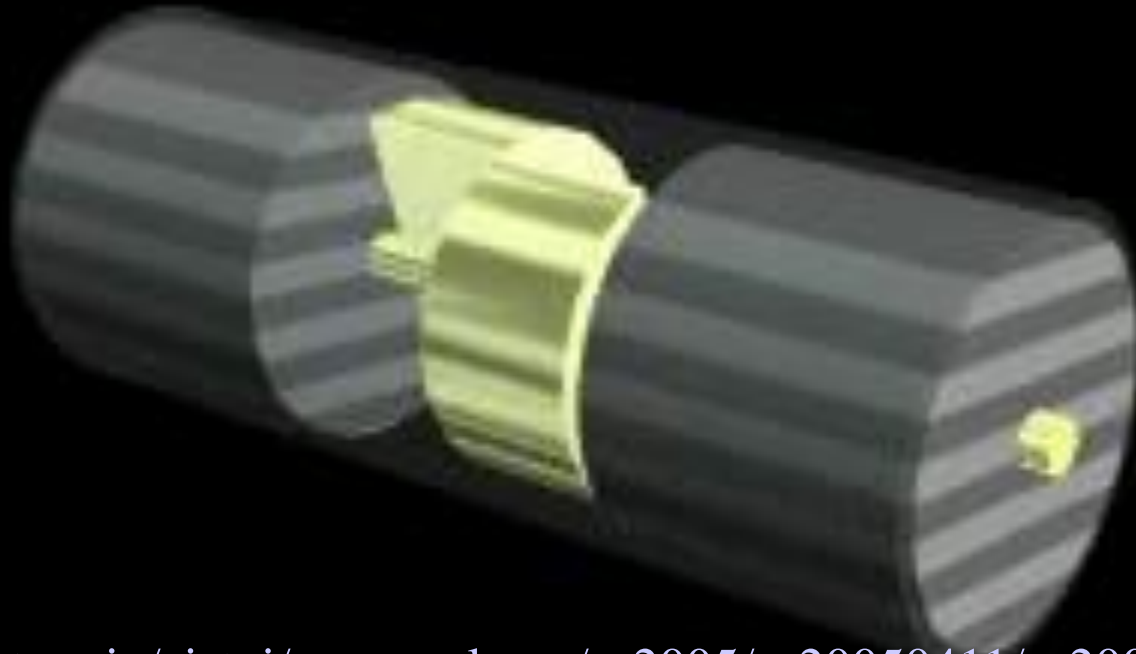

[http://www.aist.go.jp/aist\\_j/press\\_release/pr2005/pr20050411/pr20050411.html](http://www.aist.go.jp/aist_j/press_release/pr2005/pr20050411/pr20050411.html)

[http://www.aist.go.jp/aist\\_j/press\\_release/pr2010/pr20100825/pr20100825.html](http://www.aist.go.jp/aist_j/press_release/pr2010/pr20100825/pr20100825.html)

# 回転

中村 則雄: 立体視に触感・手ごたえを与える非ベース型錯触力覚インタフェースの可能性, CEDEC2010

# 局所的なトルクの提示 FlexTorque (Tsetserukou et al. 2009)

Local torque presentation

## FlexTorque



Innovative Haptic Interface for  
Realistic Physical Interaction in  
Virtual Reality

D. Tsetserukou et al: ExoInterfaces: novel exoskeleton haptic interfaces for virtual reality, augmented sport and rehabilitation, Augmented Human 2010

[http://www.youtube.com/watch?v=wTZs\\_iuKG1A&feature=related](http://www.youtube.com/watch?v=wTZs_iuKG1A&feature=related)



# 皮膚感覚による力覚の錯覚

Haptic illusion by cutaneous input

Gravity Grabber (Minamizawa et al.)

<http://www.youtube.com/watch?v=xoxbADarD4k>

# TODAY'S TOPIC

## 1. Haptic Perception Mechanism (other than skin sensation)

### a. Haptic Illusions

- I. Vision + Haptics
- II. Cutaneous+Haptics

## 2. Classifying Haptic Interface

### a. Grounded type

- I. Encounter type
- II. Wearing type
- III. Holding type (pen & tools)

### b. Ungrounded type

## 3. Application of Haptic Interface

### a. VR

### b. Telexistence & Communication

### c. AR

# What to display?

- Virtual World Information
  - CG Modeling
  - Video Game
  - Cockpit is only Necessary
- Real World Information
  - Telexistence, Remote Communication
  - Surgical Training
  - Haptics AR

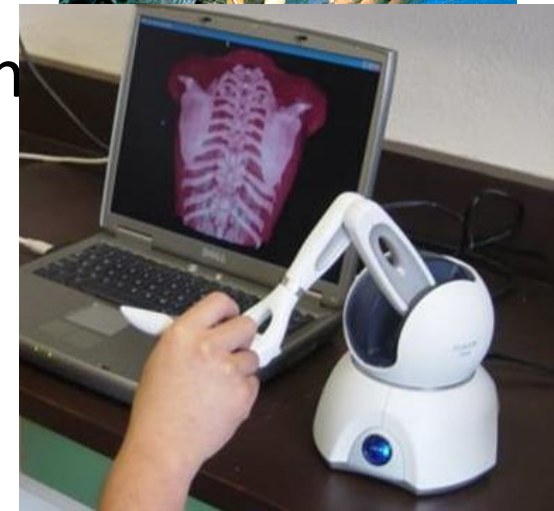
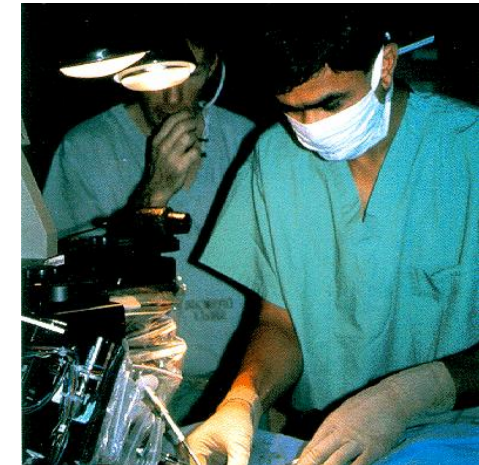
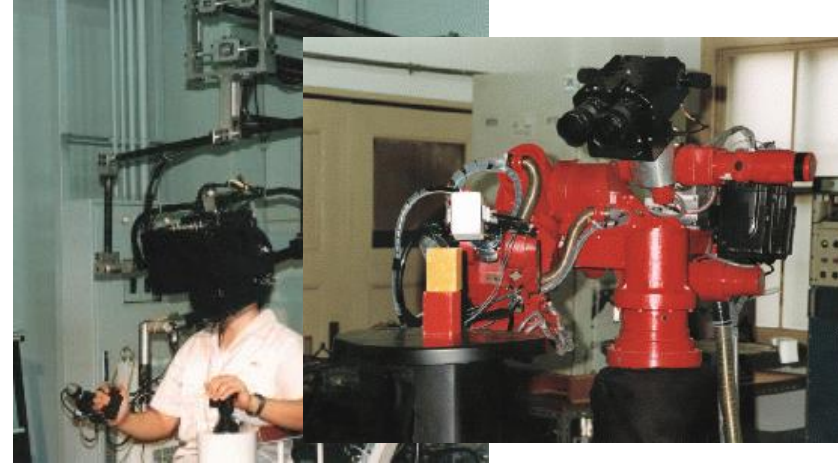

# TELESAR (Tachi et al., 1989)

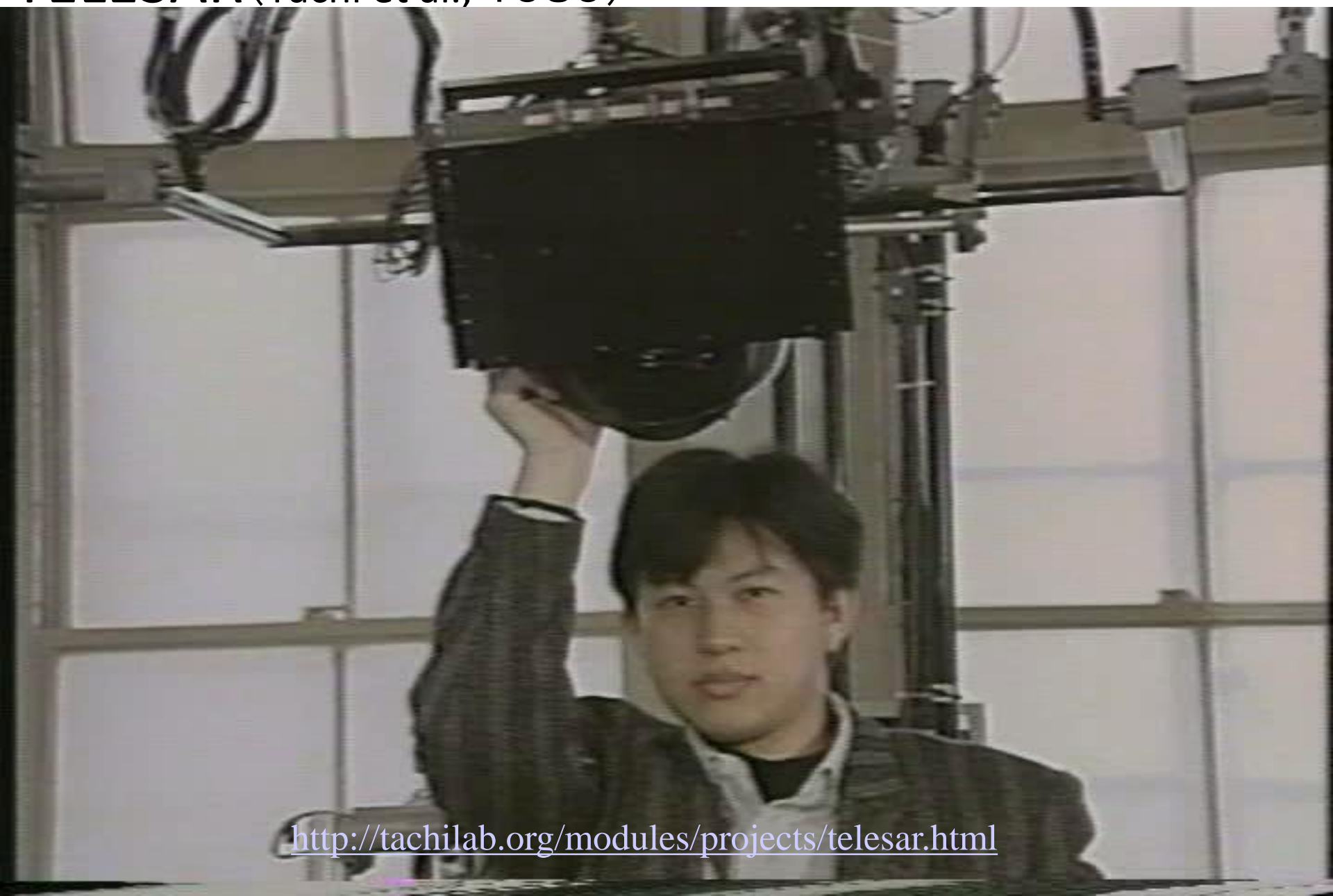

<http://tachilab.org/modules/projects/telesar.html>

# TELESAR II

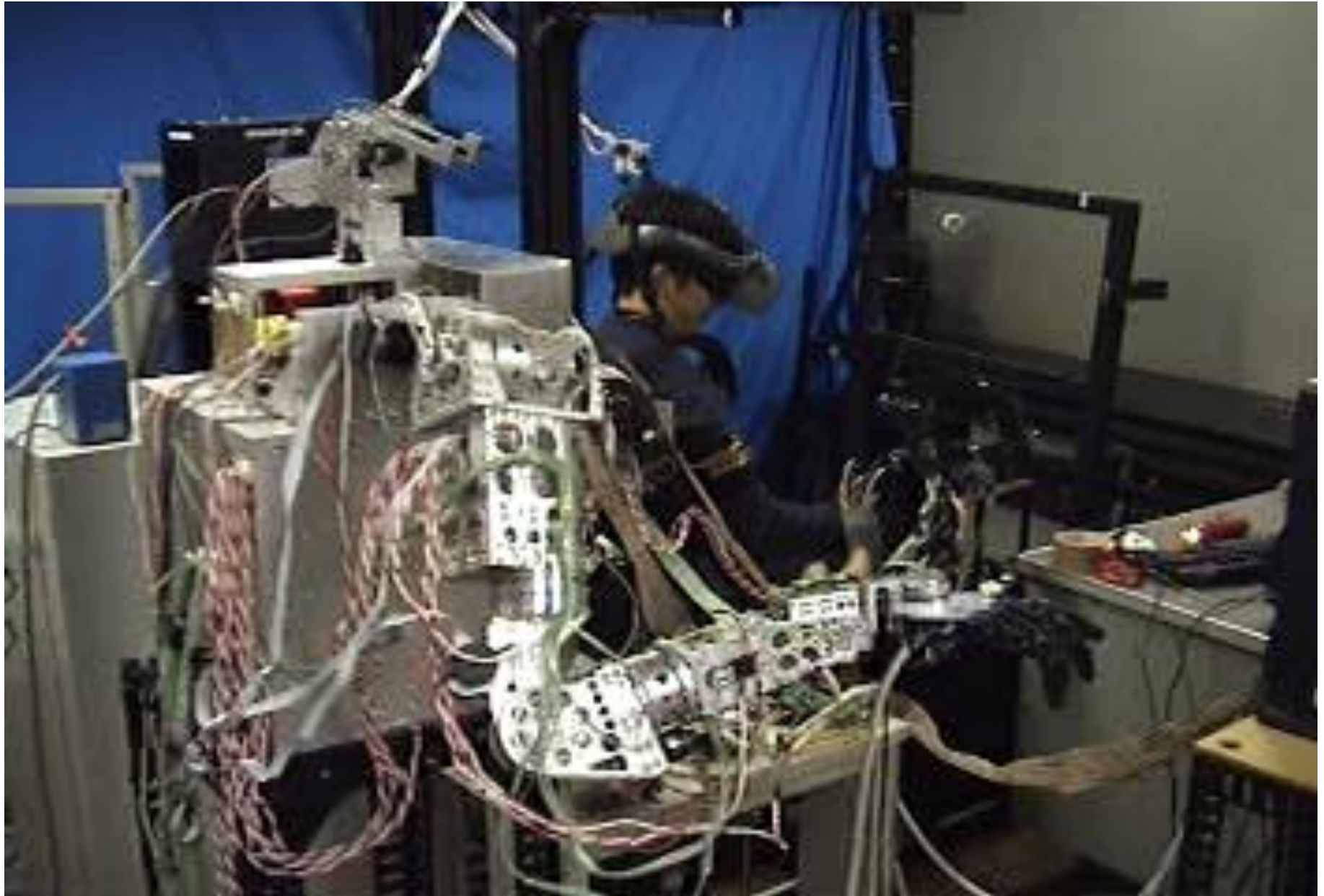



# Remote mutual communication Robotic User Interface (RobotPHONE)



# 医療応用：手術トレーニング

Medical Application: Surgical Training

静脈経路確保 Intravenous line inserision

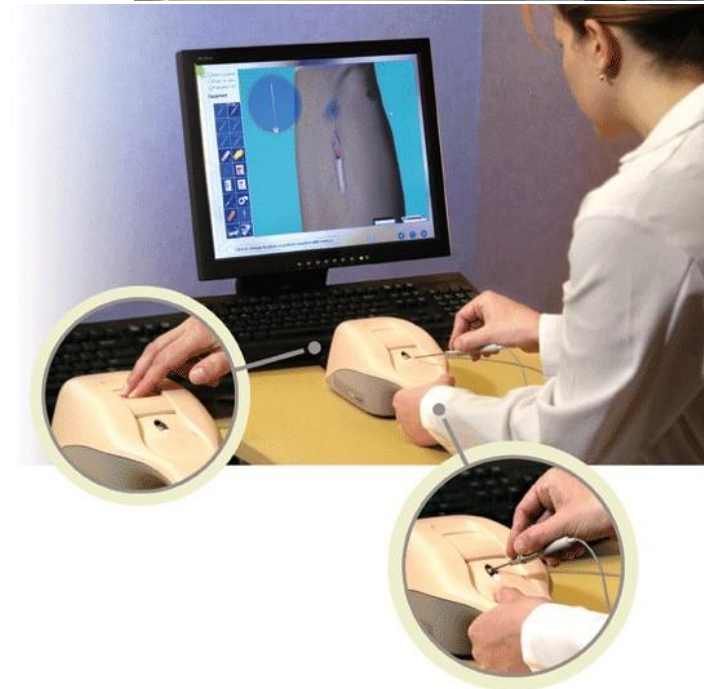

- 通常は実物大モデルでトレーニング。触覚フィードバック付きシミュレータに置き換える。
- Ordinally, training is done by real-size model. Haptic simulator will replace it.

医療応用: 手術トレーニング

Medical Application: Surgical Training

内視鏡手術 Laparoscopic Surgery

- 低侵襲だが術者にとっては座標変換など訓練が必要
- Low-invasive surgery, but operator must be trained.

# 内視鏡手術シミュレータ Laparoscopic Surgery Simulator





# ロボット遠隔手術／Robotic Tele-Surgery: da Vinci



da Vinci: 最も有名なシステム。力の提示なし。人の入力から振動を除く等のサポートはあり。

da Vinci: No force presentation. Low pass filtering of human input to eliminate vibration.





# 医療応用:まとめ / Medical Application: Summary

- 従来の医療トレーニングでは模型を多用。現在も主流。
- トレーニング用途のシミュレータで、ハプティックインタフェースが着実に普及している。
- 完全にハプティックインタフェース+CGで作る場合と、3Dプリンタの出力を組み合わせる場合とがある。
  - 3Dプリンタで模型を作ることによりリアルな触覚。ただしコスト高
- 実際の術中でのハプティックによるサポートは限定的。
- Conventional medical training used mockups, which is still prevailing way.
- Haptic interface is growing in the field of medical training
- Two strategies. (1) Pure haptic device + CG. (2) Using 3D printer output. (2) can present more realistic feeling, but still high cost.
- Haptic support during true surgery is still limited.

# Haptic AR(1): 感覚変換によって触れない物を触る

## Touching the non-touchable by sensory conversion



野嶋 琢也, 関口 大陸, 稲見 昌彦, 舘 暲: 力覚提示を利用した実時間実環境作業支援システムの提案, 日本バーチャルリアリティ学会論文誌, Vol.7, No.2, pp.193-200 (2002.5)

Haptic AR(2): カセンサと制御により柔らかさを劇的に変える  
Stiffness Modulation by using force sensor and impedance control

# Interaction with a soft sponge block

Stiffness Modulation for Haptic Augmented Stiffness Shifting: Improving the Perceived Hardness of a Virtual Surface,  
Gabjong Han, Seokhee Jeon, Seungmoon Choi, Haptics Symposium 2010

# Haptic AR(3): 木工への応用

A



B



C



[http://web.media.mit.edu/~amitz/Research/Entries/2011/11/15\\_FREE-D.html](http://web.media.mit.edu/~amitz/Research/Entries/2011/11/15_FREE-D.html)

## おわりに Summary

- ハプティックインタフェースは現在百花繚乱状態。ハードウェアとしては研究から製品にシフトしつつある。
- 特に応用を限定した場合、「道具」の再現の方が「手の形」の再現より楽。このため製品では把持型が主流。
- Numerous haptic interface is now commercially available.
- For specific application, reproducing the behaviour of “tool”, not hand, is easier, naturally leading to grip type interface.



# 小テスト／Mini Test 次回開始まで

以下の全てに100字以内程度で解答せよ／Answer all questions within 50 words

1. 拮抗筋構造の利点について説明せよ Explain merit of antagonistic muscle structure.
2. 筋紡錘の役割について説明せよ Explain role of muscle spindle
3. ゴルジ腱器官の役割について説明せよ Explain role of Golgi tendon organ.
4. サイズー重さ錯覚について説明せよ Explain size-weight illusion.
5. シュードハプティクスについて説明せよ Explain pseudo-haptics illusion
6. ラバーバンドイリュージョンについて説明せよ Explain rubber-hand illusion
7. 幻肢痛について説明せよ Explain phantom pain.
8. ハンガー反射について説明せよ Explain hanger reflex
9. 遭遇型ハプティックデバイスについて説明せよ Explain encounter type haptic device.
10. 装着型ハプティックデバイスについて説明せよ Explain wear type haptic device.
11. 装着型と把持型のハプティックデバイスの違いについて説明せよ Explain difference between wear type and grip type haptic device.
12. バックドライバビリティについて説明せよ Explain back-drivability